

14 GA. PERFORATED  
STEEL SHEET

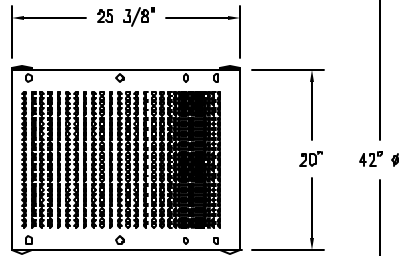

10 GA. SPUN STL.

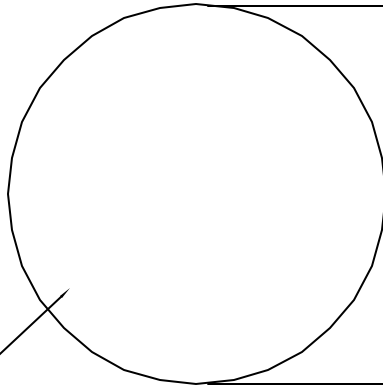
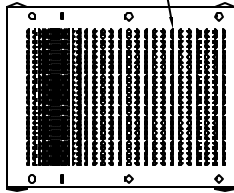
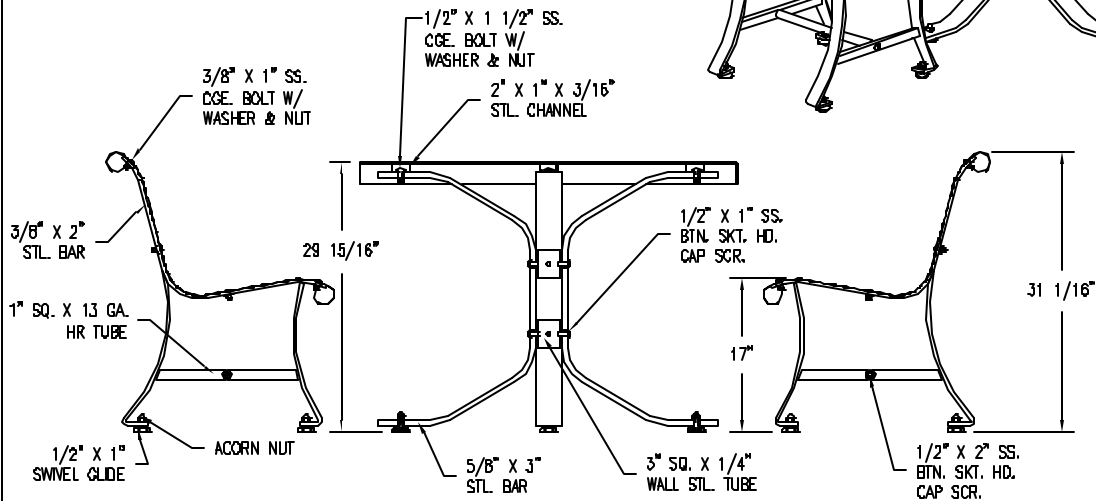

NOTES:

- 1.) ALL STL. MEMBERS COATED W/ ZINC RICH EPOXY THEN FINISHED W/ POLYESTER POWDER COATING.
- 2.)  $1/2'' \times 1''$  SWIVEL GLIDES AND  $1/2'' \times 3 \ 3/4''$  EXPANSION ANCHOR BOLTS PROVIDED.
- 3.) FOR CHAIR INSTALLATION SEE SPEC SHEET # 126-01  
FOR TABLE INSTALLATION SEE SPEC SHEET # 126-02



DuMor, inc.

P.O. Box 142 Mifflintown, PA 17059-0142

SCALE : NONE  
 DATE DRAWN : 12/20/06  
 DRAWN BY : ESS  
 DATE REV. :  
 REV. BY :

TITLE : TABLE

REV. A  
 DRAWING NUMBER 126-20

SHEET 1