

SLAT OPTIONS _____
 WOOD
 RECYCLED PLASTIC
 WOOD GRAIN RECYCLED PLASTIC

NOTES:
 1.) ALL STL. MEMBERS COATED W/ ZINC RICH EPOXY THEN FINISHED W/ POLYESTER POWDER COATING.
 2.) 1/2" X 3 3/4" EXPANSION ANCHOR BOLTS PROVIDED.



BENCH

DATE DRAWN : 12/10/21
 DRAWN BY : JSB
 DATE REV. :
 REV. BY :

REV.
 A

DRAWING
 NUMBER

520-60

SHEET
 1 OF 2

NOTES:

- 1.) DURING ASSEMBLY PROCEDURE;
DO NOT COMPLETELY TIGHTEN HARDWARE.
- 2.) THE ACTUAL PARTS WILL NOT BE NUMBERED.
NUMBERS ONLY APPLY TO DRAWING.
- 3.) UPON COMPLETION OF ASSEMBLY SQUARE
ALL COMPONENTS THEN TIGHTEN ALL HARDWARE.
- 4.) MOUNT AND ANCHOR AS SPECIFIED.

TOOLS REQ'D

- 3/4" WRENCH
- 5/16" ALLEN WRENCH
- 1/2" MASONRY DRILL BIT
- DRILL

PARTS LIST FOR S-2

ITEM	QTY	PART NO	DESCRIPTION
1	1	0-520-00-01L	STL END SUPPORT, LEFT
2	1	0-520-00-01R	STL END SUPPORT, RIGHT
3	38	0-520-00-04	2" X 4" X 15 1/8" VERT RAD SLAT
4	1	0-520-60-02	6' STL SEAT FRAME
5	1	0-520-60-03	6' STL VERT BACKREST SEAT FRAME
6	6	1-11-068	1/2" X 1" SS CGE BOLT
7	76	1-13-023	5/16" X 1 1/4" SS BTN SKT HD LAG
8	6	1-20-018	1/2" SS THIN NYLON LOCKNUT
9	6	1-22-015	1/2" SS FLAT WASHER
10	76	1-22-017	5/16" SS FLAT WASHER

KITS PROVIDED FOR S-2

ITEM	QTY	PART NO	DESCRIPTION
11	1	K-ANCO860-4	1/2" X 3 3/4" SS ANCHOR KIT (4PC)
12	2	K-BL0524-40	5/16" LAG HARDWARE KIT (40PC)
13	2	K-CG0816-4TL	1/2" CGE BOLT HARDWARE KIT (4PC)

1 ATTACH BACKREST FRAME TO SEAT FRAME.

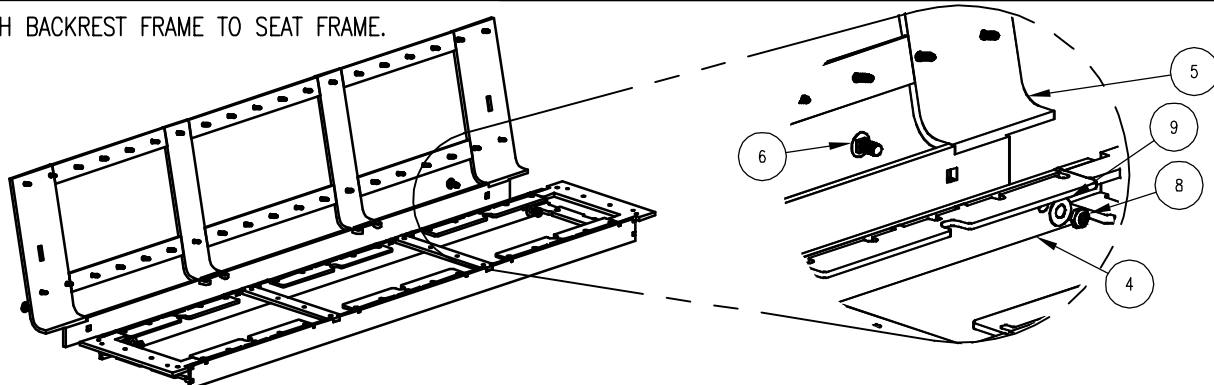

2 ATTACH SLATS TO STEP 1.

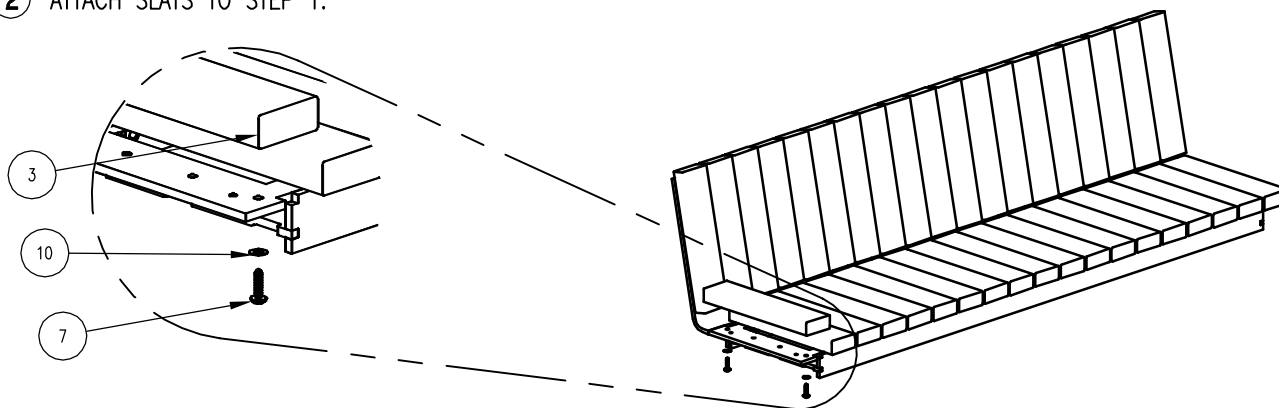

3 ATTACH SUPPORTS TO STEP 2.

