

LENGTH OPTIONS

- 6' BENCH
- 8' BENCH

NOTES

- 1.) ALL STL. MEMBERS COATED W/ ZINC RICH EPOXY THEN FINISHED W/ POLYESTER POWDER COATING.
- 2.) ALL WOOD MEMBERS TREATED W/ CLEAR PRESERVATIVE.
- 3.) 1/2" X 3 3/4" EXPANSION ANCHOR BOLTS PROVIDED FOR S-2, S-3 & S-4 OPTIONS.

WOOD OPTIONS

- 'C' & BTR. DOUGLAS FIR KD S4S EE
- IPE S4S EE
- OTHER _____

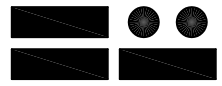
| | | | | | | |
|--|--------------|----------|---------|----------------|--------|--|
|  DuMor, inc. P.O. Box 142 Mifflintown, PA 17059-0142 | SCALE : | NONE | TITLE : | | BENCH | |
| | DATE DRAWN : | 3/22/94 | REV. | DRAWING NUMBER | | |
| | DRAWN BY : | AH | G | 34 SERIES | SHEET | |
| | DATE REV. : | 10/26/11 | | | 1 OF 2 | |
| REV. BY : | ESS | | | | | |

SURFACE MOUNT OPTION SHOWN

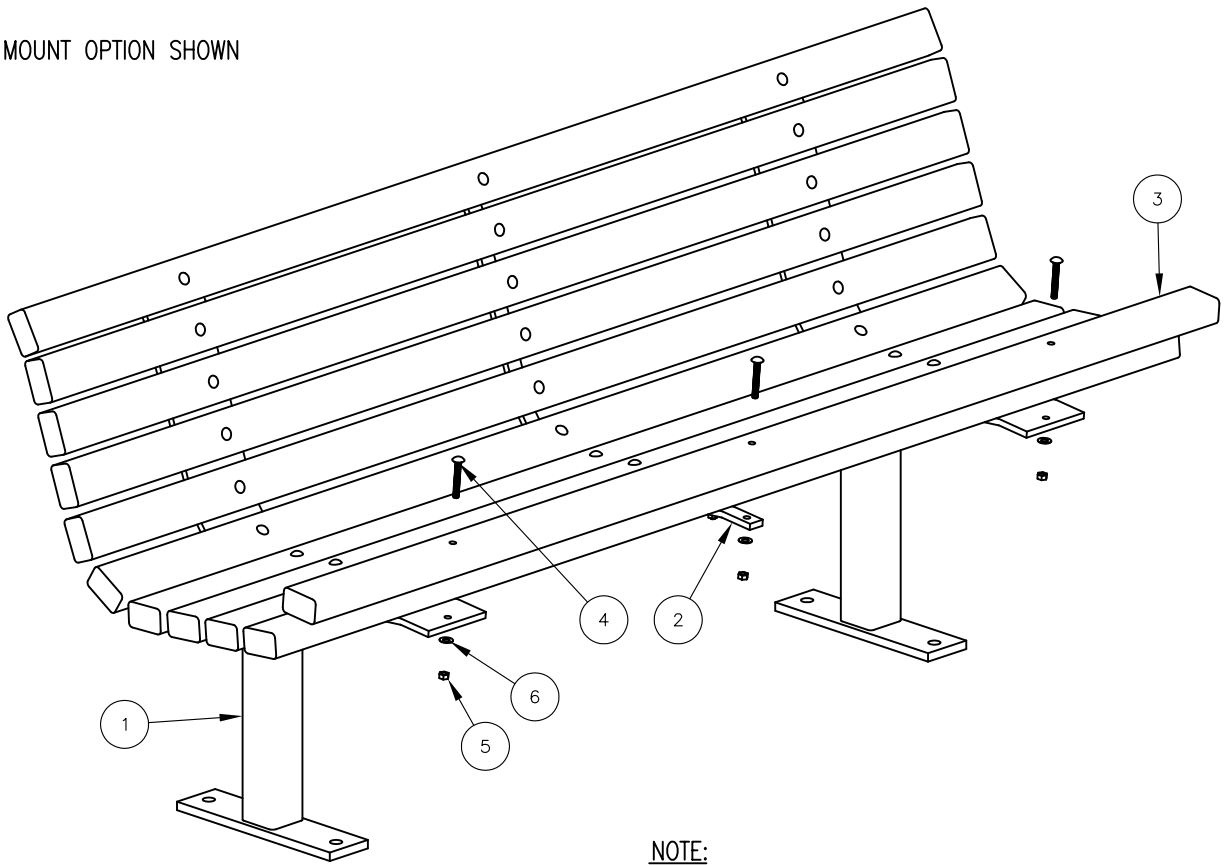

NOTE:

- 1.) DURING ASSEMBLY PROCEDURE;
DO NOT COMPLETELY TIGHTEN HARDWARE.
- 2.) THE ACTUAL PARTS WILL NOT BE NUMBERED;
NUMBERS ONLY APPLY TO DRAWING.
- 3.) SEE SPEC. SHEET 1 FOR MOUNTING OPTION.

STEP 1:

- USE 2 - PCS. SUPPORT POST FOR SURFACE MOUNT (1)
- 11 - PCS. 2" X 3" X 71" WOOD SLAT (3)
- 22 - PCS. 5/16" X 2 1/4" SS. CGE. BOLT (4)
- 22 - PCS. 5/16" SS. FLAT WASHER (6)
- 22 -PCS. 5/16" SS. HEX NUT (5)

ATTACH 2" X 3" X 71" WOOD SLAT (3) TO SUPPORT POST FOR SURFACE MOUNT (1) USING HARDWARE (4, 5 & 6). TIGHTEN TO SNUG FIT. REPEAT UNTIL ALL SLATS ARE ATTACHED TO SUPPORTS.

STEP 2:

- USE 1 - PC. CENTER CONTOUR STRAP (2)
- 11 - PCS. 5/16" X 2 1/4" SS. CGE. BOLT (4)
- 11 - PCS. 5/16" SS. FLAT WASHER (6)
- 11 - PCS. 5/16" SS. HEX NUT (5)

ATTACH CENTER CONTOUR STRAP (2) TO STEP 1 ASSEMBLY USING HARDWARE (4, 5 & 6). TIGHTEN TO SNUG FIT.

STEP 3:

UPON COMPLETION OF BENCH ASSEMBLY SQUARE ALL COMPONENTS THEN TIGHTEN ALL HARDWARE.

STEP 4:

ANCHOR ACCORDING TO SUPPORT OPTION USED.

| ITEM | QTY | PART NO | DESCRIPTION |
|------|-----|----------------|--------------------------------|
| 1 | 2 | 0-34-00-02/S-2 | SUPPORT POST FOR SURFACE MOUNT |
| 2 | 1 | 0-34-00-04 | CENTER CONTOUR STRAP |
| 3 | 11 | 0-34-60-01 | 2" X 3" X 71" WOOD SLAT |
| 4 | 33 | 1-11-062 | 5/16" X 2 1/4" SS CGE BOLT |
| 5 | 33 | 1-21-015 | 5/16" SS HEX NUT |
| 6 | 33 | 1-22-017 | 5/16" SS FLAT WASHER |

| | | | |
|--|------------------------|----------------------------------|------------------------------------|
|  DuMor, inc. P.O. Box 142 Mifflintown, PA 17059-0142 | SCALE : NONE | TITLE : BENCH ASSEMBLY | |
| | DATE DRAWN : 3/22/24 | REV. F | DRAWING NUMBER 34 SERIES |
| | DRAWN BY : AH | | |
| | DATE REV. : 12/15/08 | | |
| REV. BY : ESS | SHEET 2 OF 2 | | |