

NOTES

- 1.) GRILL FINISHED W/ HEAT RESISTANT BLACK ENAMEL.



DuMor, inc.

P.O. Box 142 Mifflintown, PA 17059-0142

SCALE : NONE  
 DATE DRAWN : 3/22/94  
 DRAWN BY : CDC  
 DATE REV. : 2/14/03  
 REV. BY : CDC

TITLE : DUAL LEVEL GRILL

REV. B DRAWING NUMBER 24-00

SHEET 1 OF 2

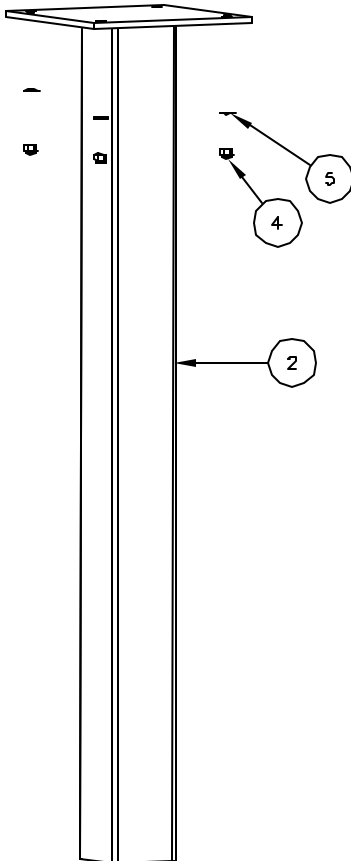
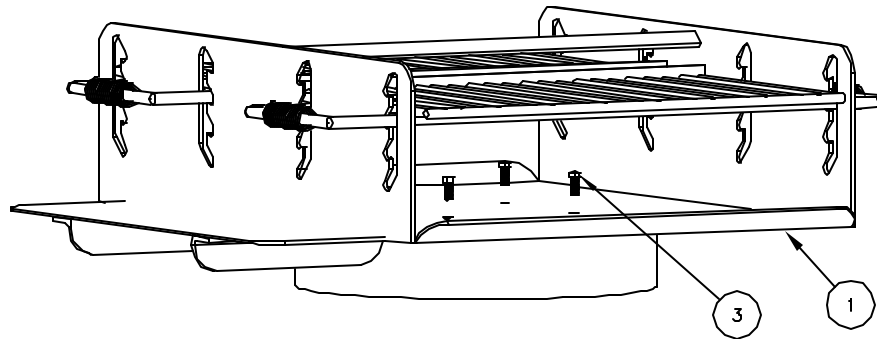

NOTE:

- 1.) DURING ASSEMBLY PROCEDURE;  
DO NOT COMPLETELY TIGHTEN HARDWARE.
- 2.) THE ACTUAL PARTS WILL NOT BE NUMBERED;  
NUMBERS ONLY APPLY TO DRAWING.

STEP 1:

USE 1 - PC. SUPPORT POST FOR EMBEDMENT ( 2 )  
MOUNT AND LEVEL EMBEDMENT POST ( 2 ) AS SPECIFIED  
ON SHEET 1.

STEP 2:

USE 1 - PC. DUAL - LEVEL GRILL BODY ASSEMBLY ( 1 )  
4 - PCS. 3/8" X 1" SS HEX HD CAP SCR. ( 3 )  
4 - PCS. 3/8" SS NYLON LOCKNUT NUT ( 4 )  
4 - PCS. 3/8" SS FLAT WASHER ( 5 )  
AFTER CONCRETE HARDENS, ATTACH DUAL GRILL ASSEMBLY  
( 1 ) TO SUPPORT POST ( 2 ) USING HARDWARE ( 3, 4 & 5 ).  
TIGHTEN TO SNUG FIT.

STEP 3:

UPON COMPLETION OF GRILL ASSEMBLY TIGHTEN ALL HARDWARE.

ITEM	QTY	PART NO	DESCRIPTION
1	1	0-24-00-01	DUAL-LEVEL GRILL BODY
2	1	0-24-00-02	SUPPORT POST FOR EMBEDMENT
3	4	1-12-018	3/8" X 1" SS HEX HD CAP SCR
4	4	1-20-007	3/8" SS NYLON LOCKNUT
5	4	1-22-024	3/8" SS FLAT WASHER

**DuMor, inc.**  
P.O. Box 142 Mifflintown, PA 17059-0142

SCALE :	NONE
DATE DRAWN :	3/22/94
DRAWN BY :	CDC
DATE REV. :	2/14/03
REV. BY :	CDC

TITLE :		DUAL-LEVEL GRILL ASSEMBLY	
REV.	DRAWING NUMBER	24-00	SHEET 2 OF 2
B			