

NOTES

- 1.) ALL STL. MEMBERS COATED W/ ZINC RICH EPOXY THEN FINISHED W/ POLYESTER POWDER COATING.
- 2.) 1/2" X 3 3/4" EXPANSION ANCHOR BOLTS PROVIDED.

**DuMor, inc.**  
P.O. Box 142 Mifflintown, PA 17059-0142

SCALE : NONE  
DATE DRAWN : 07/16/12  
DRAWN BY : RDH  
DATE REV. :  
REV. BY :

TITLE :  
REV. A

PLANTER

DRAWING NUMBER 440-17X32T

SHEET 1 OF 2

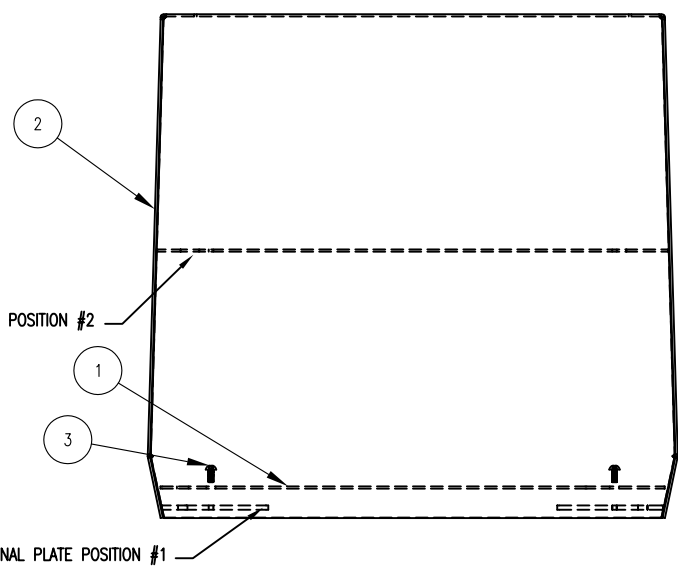
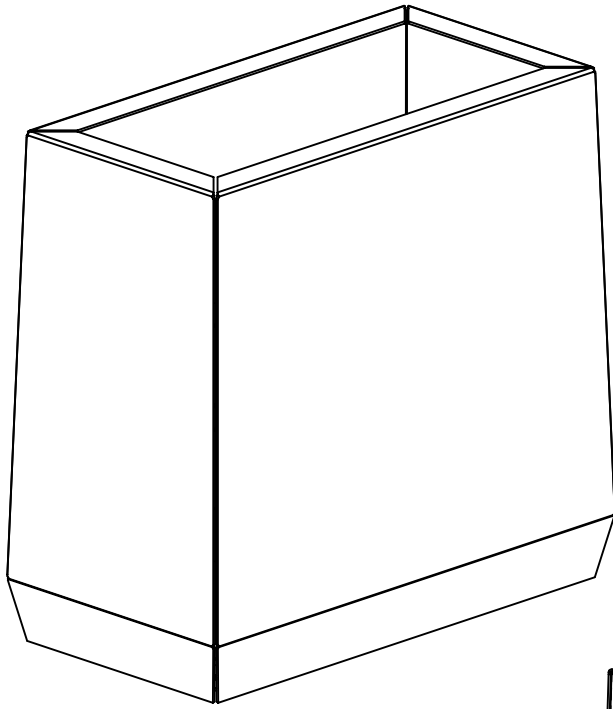

NOTE:  
 1.) THE ACTUAL PARTS WILL NOT BE NUMBERED;  
 NUMBERS ONLY APPLY TO DRAWING.

**STEP 1:**  
 USE 1 - PC. STL. PLANTER BODY ( 1 )  
 1 - PC. STL. BOLT ON PLATE ( 2 )  
 2 - PCS. 5/16" X 3/4" S.STL. BTN. SKT. HD. CAP SCR. ( 3 )  
 ATTACH STL. BOLT ON PLATE ( 2 ), \*\*SEE OPTIONAL PLATE POSITION LOCATIONS\*\*, TO  
 STL. PLANTER BODY ( 1 ), USING 5/16" X 3/4" S.STL. BTN.  
 SKT HD. CAP SCREWS ( 3 ).

**STEP 2:**  
 MOUNT AND ANCHOR AS SPECIFIED.

ITEM	QTY	PART NO	DESCRIPTION
1	1	0-440-17X32S-02	STL BOLT ON PLATE
2	1	0-440-17X32T-01	STL PLANTER BODY ( 17" X 32" X 30" )
3	2	1-12-089	5/16" X 3/4" SS BTN SKT HD CAP SCR
4	1	K-ANC0860-4	1/2" X 3 3/4" SS ANCHOR KIT (4PC)
5	1	K-BC0512-2	5/16" CAP HARDWARE KIT (2PC)

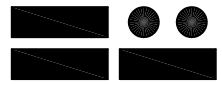
 <b>DuMor, inc.</b> P.O. Box 142 Mifflintown, PA 17059-0142	SCALE :	NONE	TITLE :		PLANTER	
	DATE DRAWN :	07/16/12	REV.	DRAWING NUMBER	440-17X32T	SHEET
	DRAWN BY :	RDH	A			2 OF 2
	DATE REV. :					
	REV. BY :					