

NOTES

- 1.) ALL STL. MEMBERS COATED W/ ZINC RICH EPOXY THEN FINISHED W/ POLYESTER POWDER COATING.
- 2.) 1/2" X 3 3/4" EXPANSION ANCHOR BOLTS PROVIDED.

DuMor, inc.
P.O. Box 142 Mifflintown, PA 17059-0142

SCALE : NONE
 DATE DRAWN : 07/16/12
 DRAWN BY : RDH
 DATE REV. :
 REV. BY :

TITLE : PLANTER
 REV. A
 DRAWING NUMBER 440-17X32S

SHEET
1 OF 2

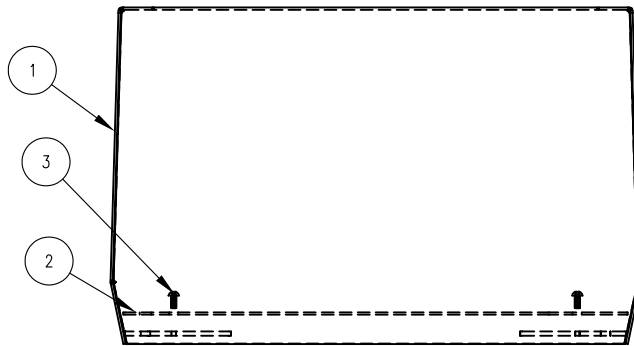
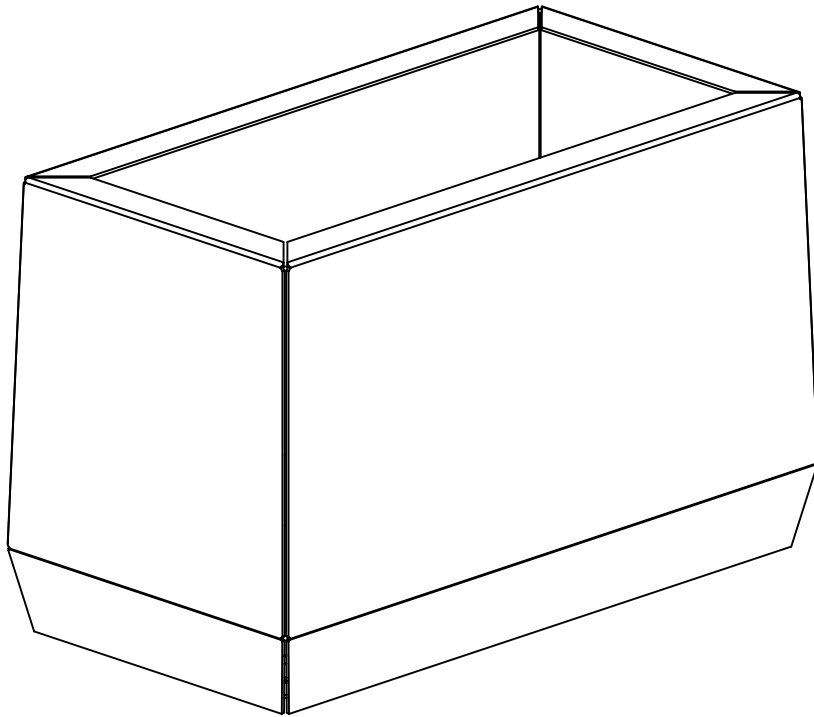

NOTE:

1.) THE ACTUAL PARTS WILL NOT BE NUMBERED;
NUMBERS ONLY APPLY TO DRAWING.

STEP 1:

USE 1 - PC. STL. PLANTER BODY (1)
 1 - PC. STL. BOLT ON PLATE (2)
 2 - PCS. 5/16" X 3/4" S.STL. BTN. SKT. HD. CAP SCR. (3)
 ATTACH STL. BOLT ON PLATE (2) TO
 STL. PLANTER BODY (1), USING 5/16" X 3/4" S.STL. BTN.
 SKT HD. CAP SCREWS (3).

STEP 2:

MOUNT AND ANCHOR AS SPECIFIED.

ITEM	QTY	PART NO	DESCRIPTION
1	1	0-440-17X32S-01	STL PLANTER BODY (17" X 32" X 20")
2	1	0-440-17X32S-02	STL BOLT ON PLATE
3	2	1-12-089	5/16" X 3/4" SS BTN SKT HD CAP SCR
4	1	K-ANC0860-4	1/2" X 3 3/4" SS ANCHOR KIT (4PC)
5	1	K-BC0512-2	5/16" CAP HARDWARE KIT (2PC)

 DuMor, inc. P.O. Box 142 Mifflintown, PA 17059-0142	SCALE :	NONE	TITLE :		PLANTER	
	DATE DRAWN :	07/16/12	REV.	DRAWING NUMBER	440-17X32S	SHEET 2 OF 2
	DRAWN BY :	RDH	A			
	DATE REV. :					
	REV. BY :					