

NOTES

- 1.) ALL STL. MEMBERS COATED W/ ZINC RICH EPOXY THEN FINISHED W/ POLYESTER POWDER COATING.

NOTES:

- 1.) DURING ASSEMBLY PROCEDURE;
DO NOT COMPLETELY TIGHTEN HARDWARE.
- 2.) THE ACTUAL PARTS WILL NOT BE NUMBERED.
NUMBERS ONLY APPLY TO DRAWING.
- 3.) UPON COMPLETION OF ASSEMBLY SQUARE
ALL COMPONENTS THEN TIGHTEN ALL HARDWARE.
- 4.) MOUNT AND ANCHOR AS SPECIFIED.

TOOLS REQ'D

- 3/4" WRENCH
- 5/16 ALLEN WRENCH

PARTS LIST

ITEM	QTY	PART NO	DESCRIPTION
1	1	0-514-50-04	STL TABLE SUB FRAME
2	1	0-514-50-05	STL TABLE TOP
3	2	0-515-50-00	STL TABLE FRAME ASSEMBLY, HIGH
4	1	0-PB12-54-00	3/4" SCH 40 PIPE BRACE (54")
5	2	1-11-042	1/2" X 1 1/2" SS CGE BOLT
6	2	1-12-014	1/2" X 1" SS FLT SKT HD CAP SCR
7	8	1-12-056	1/2" X 1" SS BTN SKT HD CAP SCR
8	2	1-20-015	1/2" SS NYLON LOCKNUT
9	2	1-22-015	1/2" SS FLAT WASHER

KITS PROVIDED

ITEM	QTY	PART NO	DESCRIPTION
10	1	K-BC0816-8W	1/2" CAP HARDWARE KIT W WASHER (8PC)
11	1	K-CG0824-2L	1/2" CGE BOLT HARDWARE KIT (2PC)
12	1	K-FC0816-2	1/2" CAP HARDWARE KIT (2 PCS)

① ATTACH TABLE FRAMES TOGETHER. ATTACH PIPE BRACE.

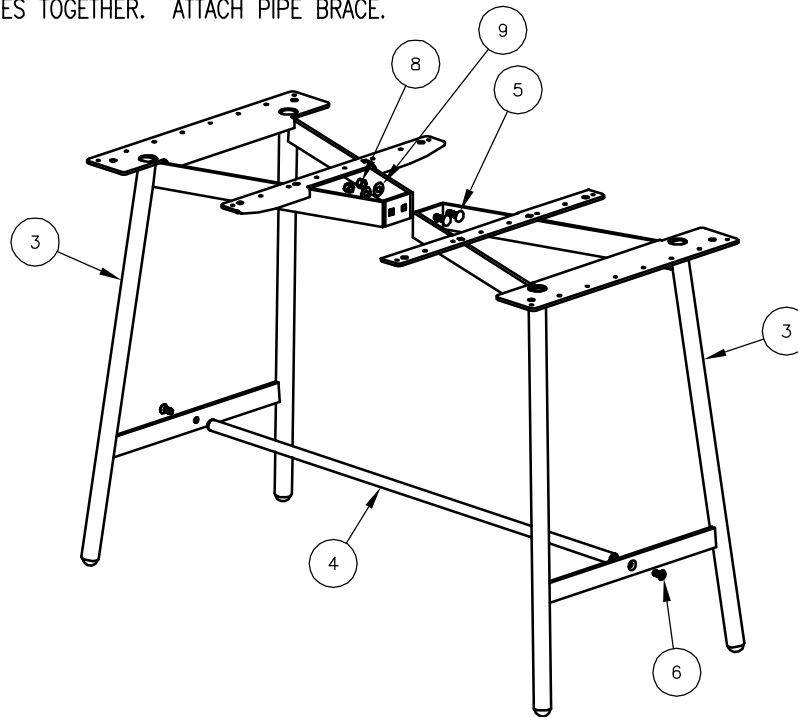

② ATTACH SUB FRAME & TABLE TOP TO STEP 1.

