

**NOTES**

- 1.) ALL STL. MEMBERS COATED W/ ZINC RICH EPOXY THEN FINISHED W/ POLYESTER POWDER COATING.

**WOOD OPTIONS**

- IPE S4S EE
- OTHER \_\_\_\_\_

**NOTES:**

- 1.) DURING ASSEMBLY PROCEDURE;  
DO NOT COMPLETELY TIGHTEN HARDWARE.
- 2.) THE ACTUAL PARTS WILL NOT BE NUMBERED.  
NUMBERS ONLY APPLY TO DRAWING.
- 3.) UPON COMPLETION OF ASSEMBLY SQUARE  
ALL COMPONENTS THEN TIGHTEN ALL HARDWARE.
- 4.) MOUNT AND ANCHOR AS SPECIFIED.

**TOOLS REQ'D**

- 3/4" WRENCH
- 3/8" HEX DRIVE

**PARTS LIST**

ITEM	QTY	PART NO	DESCRIPTION
1	2	0-514-50-00	STL TABLE FRAME ASSEMBLY
2	6	0-514-50-02	1" X 4" X 59" TABLE SLAT, WOOD
3	2	0-514-50-03	1" X 4" X 59" TABLE EDGE SLAT, WOOD
4	2	1-11-042	1/2" X 1 1/2" SS CGE BOLT
5	32	1-16-023	#14 X 7/8 SS HX WASH HD 'A' SLTD WD SCREW
6	2	1-20-015	1/2" SS NYLON LOCKNUT
7	2	1-22-015	1/2" SS FLAT WASHER

**KITS PROVIDED**

ITEM	QTY	PART NO	DESCRIPTION
8	1	K-CG0824-2L	1/2" CGE BOLT HARDWARE KIT (2PC)
9	2	K-WS1414-16	#14 HEX HD WASH WOOD SCR ( 16PC )

**1** ATTACH TABLE FRAMES TOGETHER.

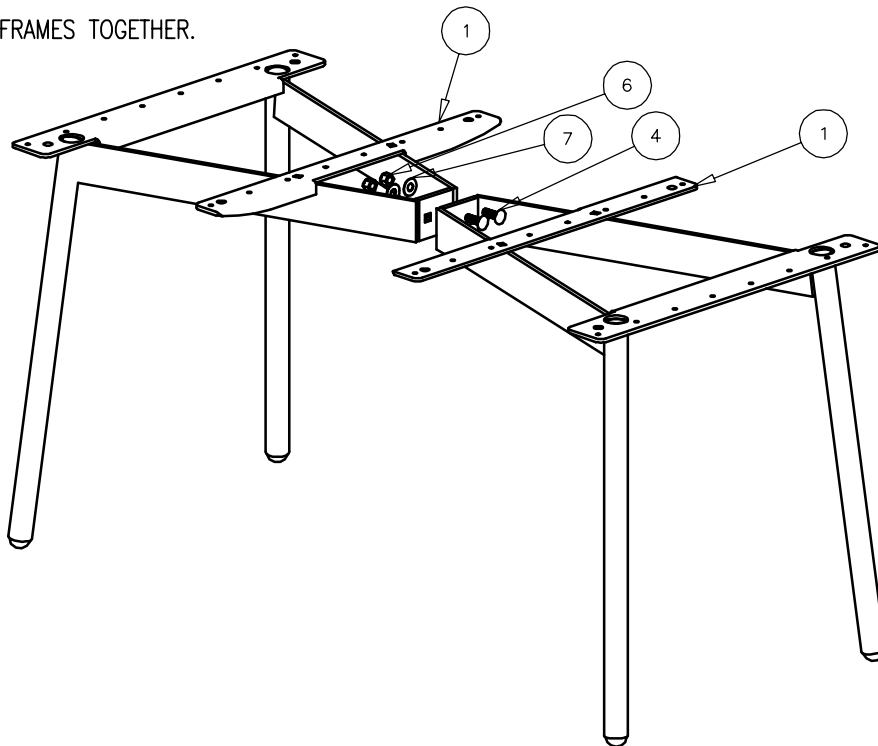

**2** ATTACH SLATS TO STEP 1 ASSEMBLY.

