

1" X 4" (NOM.) SLATS
(SEE SLAT OPTIONS)

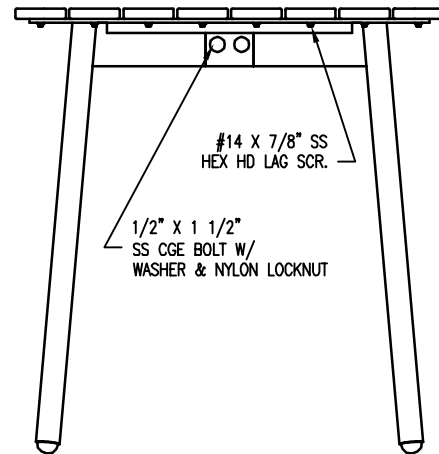
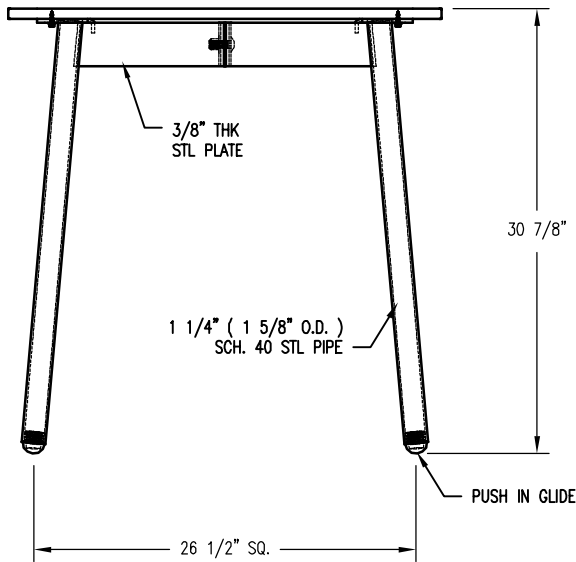
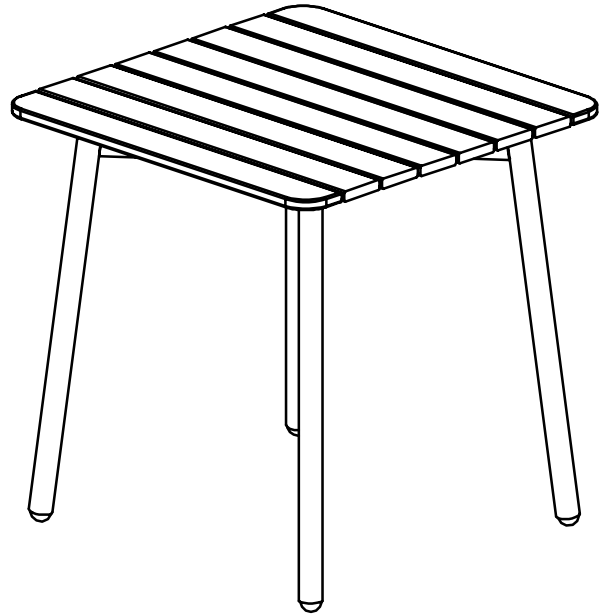

NOTES

1.) ALL STL. MEMBERS COATED W/ ZINC RICH EPOXY THEN FINISHED W/ POLYESTER POWDER COATING.

SLAT OPTIONS

- ANTIQUE MAHOGANY TEXTURED
- BRAZILIAN WALNUT TEXTURED
- OTHER _____



TABLE

DATE DRAWN : 10/28/20
DRAWN BY : RDH
DATE REV. :
REV. BY :

REV.
A

DRAWING
NUMBER

514-30TX

SHEET
1 OF 2

NOTES:

- 1.) DURING ASSEMBLY PROCEDURE;
DO NOT COMPLETELY TIGHTEN HARDWARE.
- 2.) THE ACTUAL PARTS WILL NOT BE NUMBERED.
NUMBERS ONLY APPLY TO DRAWING.
- 3.) UPON COMPLETION OF ASSEMBLY SQUARE
ALL COMPONENTS THEN TIGHTEN ALL HARDWARE.
- 4.) MOUNT AND ANCHOR AS SPECIFIED.

TOOLS REQ'D

- 3/4" WRENCH
- 3/8" HEX DRIVE

PARTS LIST

ITEM	QTY	PART NO	DESCRIPTION
1	2	0-514-30-00	STL TABLE FRAME ASSEMBLY
2	6	0-514-30TX-02	1" X 4" X 30" TABLE SLAT, TX
3	2	0-514-30TX-03	1" X 4" X 30" TABLE EDGE SLAT, TX
4	2	1-11-042	1/2" X 1 1/2" SS CGE BOLT
5	16	1-16-023	#14 X 7/8 SS HX WASH HD 'A' SLTD WD SCREW
6	2	1-20-015	1/2" SS NYLON LOCKNUT
7	2	1-22-015	1/2" SS FLAT WASHER

KITS PROVIDED

ITEM	QTY	PART NO	DESCRIPTION
8	1	K-CG0824-2L	1/2" CGE BOLT HARDWARE KIT (2PC)
9	1	K-WS1414-16	#14 HEX HD WASH WOOD SCR (16PC)

1 ATTACH TABLE FRAMES TOGETHER.

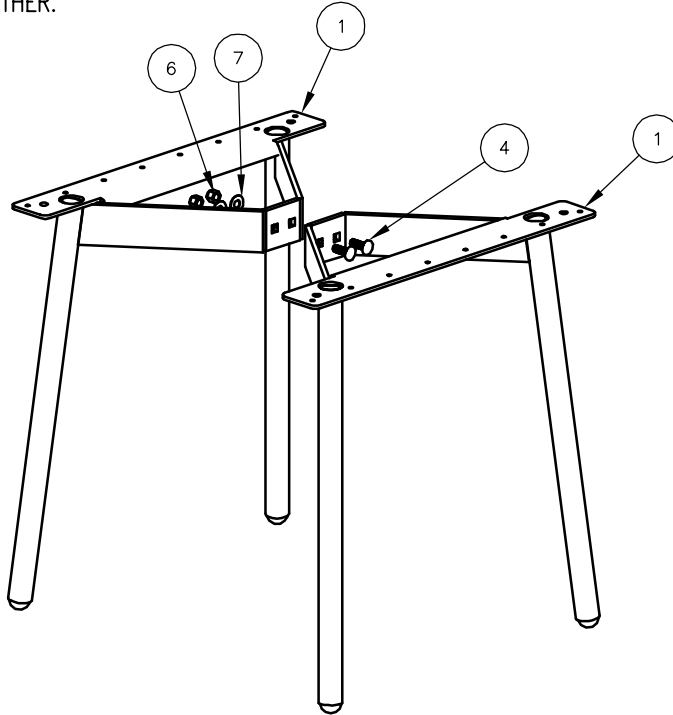

2 ATTACH SLATS TO STEP 1 ASSEMBLY.

