

**NOTES:**

- 1.) ALL STL. MEMBERS COATED W/ ZINC RICH EPOXY THEN FINISHED W/ POLYESTER POWDER COATING.
- 2.) 1/2" X 3 3/4" EXPANSION ANCHOR BOLTS PROVIDED.

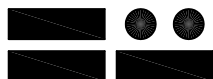

**DuMor, inc.**

P.O. Box 142 Mifflintown, PA 17059-0142

SCALE : NONE  
 DATE DRAWN : 9/10/99  
 DRAWN BY : HD  
 DATE REV. : 11/28/12  
 REV. BY : JSB

TITLE : PLANTER

REV. F

DRAWING NUMBER 114-00

SHEET 1 OF 2

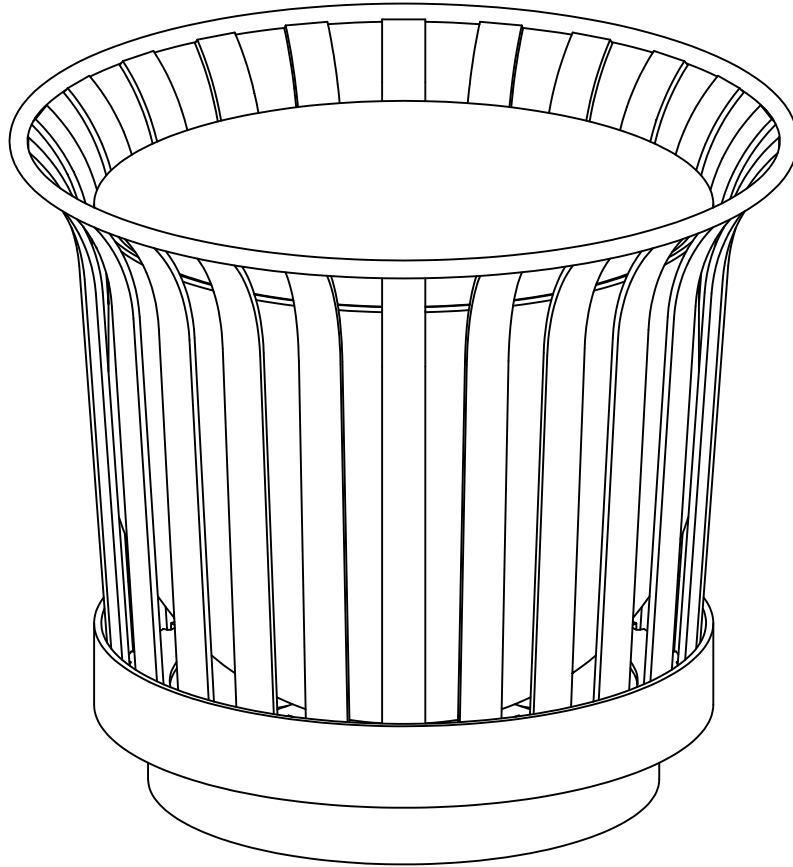

- NOTE:
- 1.) SHIPPED FULLY ASSEMBLED.
  - 2.) MOUNT AND ANCHOR AS SPECIFIED.

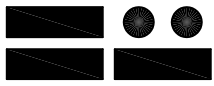
 <b>DuMor, inc.</b> P.O. Box 142 Mifflintown, PA 17059-0142	SCALE :	NONE	TITLE :		PLANTER ASSEMBLY		
	DATE DRAWN :	9/10/99	REV.	DRAWING NUMBER	114-00		
	DRAWN BY :	HD	F				
	DATE REV. :	11/28/12					
REV. BY :	JSB					SHEET	2 OF 2