

1/4" THK. STL. PLATE W/  
1 1/16" Ø ANCHOR HOLE  
( 3-PLACES )

1 1/2" THK. ( NOM. ) SLATS  
( SEE WOOD OPTIONS )

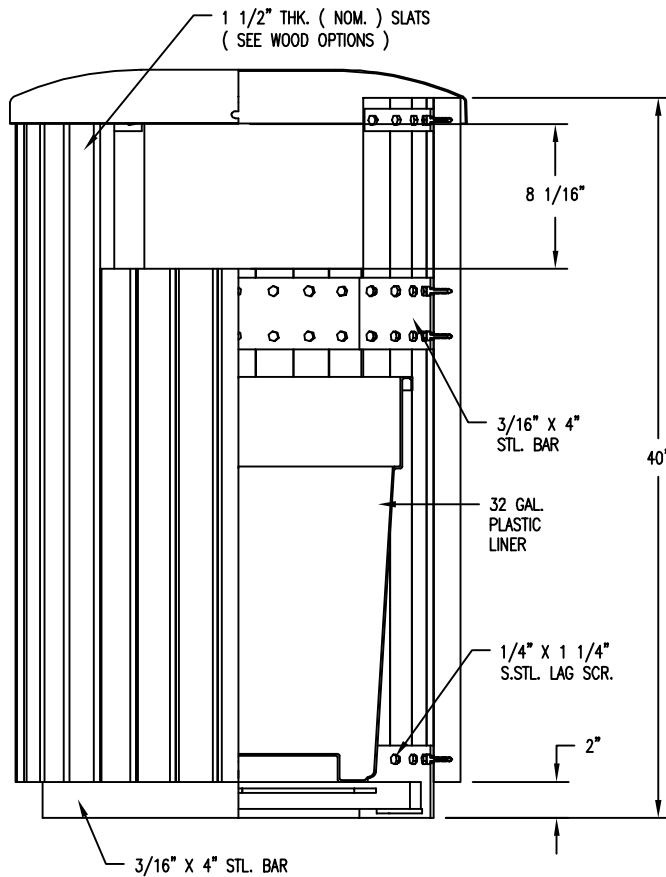

14GA SPUN  
STL COVER

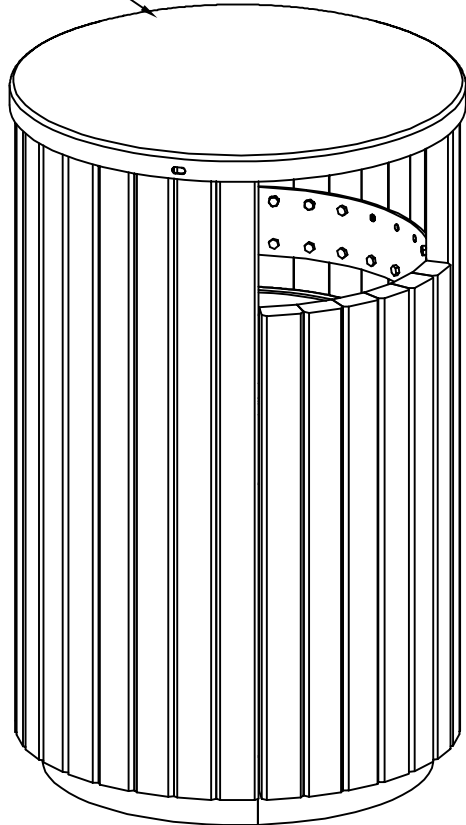

**NOTES**

- 1.) ALL STL. MEMBERS COATED W/ ZINC RICH EPOXY THEN FINISHED W/ BLACK POLYESTER POWDER COATING.
- 2.) 1/2" X 3 3/4" EXPANSION ANCHOR BOLTS PROVIDED.
- 3.) RECEPTACLE FULLY ASSEMBLED AT FACTORY.

**SLAT OPTIONS**

- ANTIQUE MAHOGANY TEXTURED
- BRAZILIAN WALNUT TEXTURED
- OTHER \_\_\_\_\_



RECEPTACLE

DATE DRAWN : 10/20/20  
DRAWN BY : JSB  
DATE REV. :  
REV. BY :

REV.  
A

DRAWING NUMBER  
70-22TX-S0  
W/ CVN-30-FTC

SHEET  
1 OF 2

PARTS LIST

ITEM	QTY	PART NO	DESCRIPTION
1	1	0-70-20TX-S0	20 GAL. RECEPTACLE ASSEMBLY, SIDE OPENING, TX
2	1	49-22	22 GAL. PL. LINER W/HANDLE, BLK

TOOLS REQ'D

3/4" WRENCH  
 1/2" MASONRY DRILL BIT  
 DRILL

NOTES:

- 1.) THE ACTUAL PARTS WILL NOT BE NUMBERED. NUMBERS ONLY APPLY TO DRAWING.
- 2.) MOUNT AND ANCHOR AS SPECIFIED.

KITS PROVIDED

ITEM	QTY	PART NO	DESCRIPTION
3	1	K-ANC0860-3	1/2" X 3 3/4" SS ANCHOR KIT (3PCS)

