

SLAT OPTIONS

- ANTIQUE MAHOGANY TEXTURED
- BRAZILIAN WALNUT TEXTURED
- OTHER _____

NOTES:

- 1.) ALL STL. MEMBERS COATED W/ ZINC RICH EPOXY THEN FINISHED W/ POLYESTER POWDER COATING.
- 2.) 1/2" X 2 1/2" NYLON GLIDES AND 1/2" X 5 1/2" EXPANSION ANCHOR BOLTS PROVIDED.

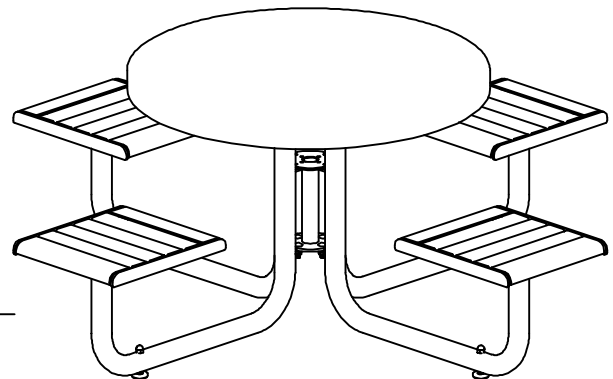

NOTE:

- 1.) DURING ASSEMBLY PROCEDURE;
DO NOT COMPLETELY TIGHTEN HARDWARE.
- 2.) THE ACTUAL PARTS WILL NOT BE NUMBERED.
NUMBERS ONLY APPLY TO DRAWING.
- 3.) UPON COMPLETION OF ASSEMBLY SQUARE
ALL COMPONENTS THEN TIGHTEN ALL HARDWARE.
- 4.) MOUNT AND ANCHOR AS SPECIFIED.

TOOLS REQ'D

- 3/4" WRENCH
- 1/2" WRENCH
- 5/16" NUT DRIVER
- 1/2" MASONRY DRILL BIT
DRILL

PARTS LIST

ITEM	QTY	PART NO	DESCRIPTION
1	1	0-101-00-01	42" DIA STL TABLE TOP
2	4	0-101-00-05	PIPE CLAMP (101)
4	4	0-294-00-01	SUPPORT FRAME / 1-SEAT
5	16	0-294-00TX-04	15 1/4" SEAT SLAT, TX
6	4	0-295-00-03	BKLS STL SEAT FRAME FOR WOOD
7	8	1-11-032	5/16" X 1" SS CGE BOLT
8	12	1-11-042	1/2" X 1 1/2" SS CGE BOLT
9	32	1-16-023	#14 X 7/8 SS HX WASH HD 'A' SLTD WD SCREW
10	12	1-20-015	1/2" SS NYLON LOCKNUT
11	8	1-20-016	5/16" SS NYLON LOCKNUT
12	4	1-21-019	1/2" SS HEX ACORN NUT
13	12	1-22-015	1/2" SS FLAT WASHER
14	8	1-22-017	5/16" SS FLAT WASHER
15	4	5-48-077	1/2" X 2 1/2" GLIDE
3	1	0-101-40-15	STL SUPPORT FOR 4 SEAT TABLE

KITS PROVIDED

ITEM	QTY	PART NO	DESCRIPTION
16	1	K-ANCO888-4	1/2" X 5 1/2" SS ANCH KIT (4PCS)
17	1	K-CG0516-8L	5/16" CGE BOLT HARDWARE KIT (8PC)
18	4	K-CG0824-4L	1/2" CGE BOLT HARDWARE KIT (4)
19	1	K-GL0840-4A	1/2" X 2 1/2" GLIDE KIT (4PCS)
20	4	K-WS1414-16	#14 HEX HD WASH WOOD SCR (16PC)

① ATTACH FRAMES TOGETHER. ATTACH GLIDES, UNLESS ANCHORING.

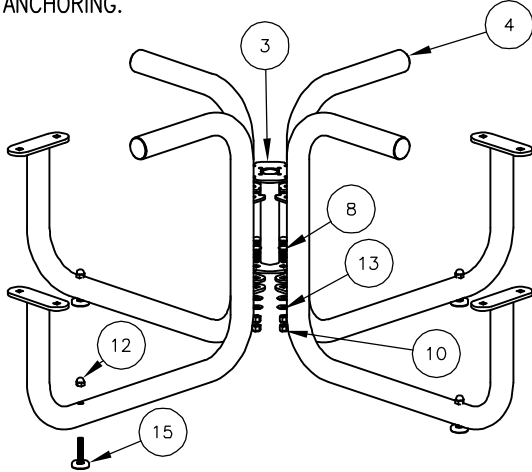

② ATTACH TABLE TOP TO STEP 1.

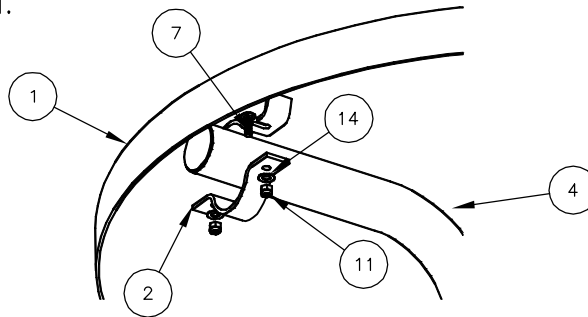

③ ATTACH SEAT FRAMES TO STEP 2.

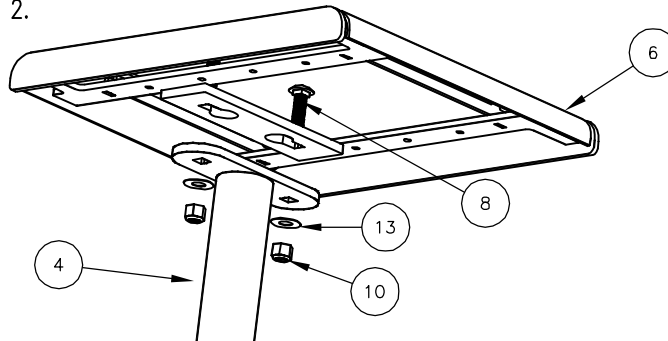

④ ATTACH SEAT SLATS TO STEP 3.

