

NOTES:

- 1.) ALL STL. MEMBERS COATED W/ ZINC RICH EPOXY THEN FINISHED W/ POLYESTER POWDER COATING.
- 2.) 1/2" X 2 1/2" NYLON GLIDES AND 1/2" X 5 1/2" EXPANSION ANCHOR BOLTS PROVIDED.

NOTE:

- 1.) DURING ASSEMBLY PROCEDURE;
DO NOT COMPLETELY TIGHTEN HARDWARE.
- 2.) THE ACTUAL PARTS WILL NOT BE NUMBERED.
NUMBERS ONLY APPLY TO DRAWING.
- 3.) UPON COMPLETION OF ASSEMBLY SQUARE
ALL COMPONENTS THEN TIGHTEN ALL HARDWARE.
- 4.) MOUNT AND ANCHOR AS SPECIFIED.

TOOLS REQ'D

- 3/4" WRENCH
- 1/2" WRENCH
- 1/2" MASONRY DRILL BIT
- DRILL

PARTS LIST

| ITEM | QTY | PART NO | DESCRIPTION |
|------|-----|---------------|------------------------------|
| 1 | 1 | 0-101-00-01 | 42" DIA STL TABLE TOP |
| 2 | 4 | 0-101-00-05 | PIPE CLAMP (101) |
| 4 | 4 | 0-294-00-01 | SUPPORT FRAME / 1-SEAT |
| 5 | 4 | 0-295-00-03HS | 16" STL BKLS SEAT |
| 6 | 8 | 1-11-032 | 5/16" X 1" SS CGE BOLT |
| 7 | 12 | 1-11-042 | 1/2" X 1 1/2" SS CGE BOLT |
| 8 | 12 | 1-20-015 | 1/2" SS NYLON LOCKNUT |
| 9 | 8 | 1-20-016 | 5/16" SS NYLON LOCKNUT |
| 10 | 4 | 1-21-019 | 1/2" SS HEX ACORN NUT |
| 11 | 12 | 1-22-015 | 1/2" SS FLAT WASHER |
| 12 | 8 | 1-22-017 | 5/16" SS FLAT WASHER |
| 13 | 4 | 5-48-077 | 1/2" X 2 1/2" GLIDE |
| 3 | 1 | 0-101-40-15 | STL SUPPORT FOR 4 SEAT TABLE |

① ATTACH FRAMES TOGETHER. ATTACH GLIDES, UNLESS ANCHORING.

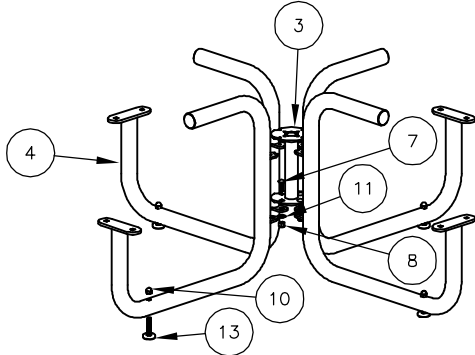

KITS PROVIDED

| ITEM | QTY | PART NO | DESCRIPTION |
|------|-----|-------------|-----------------------------------|
| 14 | 1 | K-ANCO888-4 | 1/2" X 5 1/2" SS ANCH KIT (4PCS) |
| 15 | 1 | K-CG0516-BL | 5/16" CGE BOLT HARDWARE KIT (8PC) |
| 16 | 4 | K-CG0824-4L | 1/2" CGE BOLT HARDWARE KIT (4) |
| 17 | 1 | K-GL0840-4A | 1/2" X 2 1/2" GLIDE KIT (4PCS) |

② ATTACH TABLE TOP TO STEP 1.

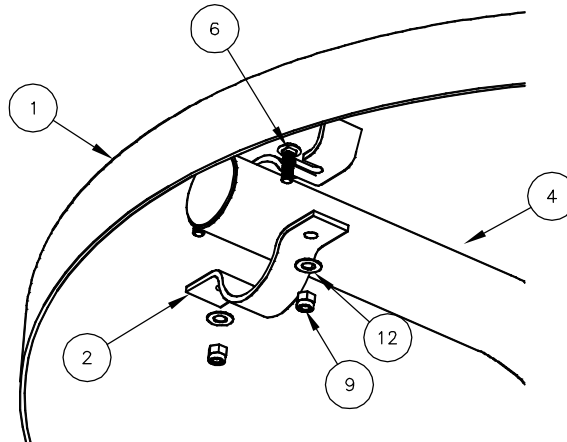

③ ATTACH SEAT TO STEP 2.

