

NOTES

- 1.) ALL STL. MEMBERS COATED W/ ZINC RICH EPOXY THEN POLYESTER POWDER COATED
- 2.) 1/2" X 3 3/4" EXPANSION ANCHOR BOLTS PROVIDED.

 DuMor, inc. P.O. Box 142 Mifflintown, PA 17059-0142	SCALE :	NONE	TITLE :		BENCH
	DATE DRAWN :	10/26/99	REV.	DRAWING NUMBER	
	DRAWN BY :	JSB	F	127-30/S-7	SHEET
	DATE REV. :	9/2/08	REV. BY :	AWH	1 OF 2

NOTE:

- 1.) DURING ASSEMBLY PROCEDURE;
DO NOT COMPLETELY TIGHTEN HARDWARE.
- 2.) THE ACTUAL PARTS WILL NOT BE NUMBERED.
NUMBERS ONLY APPLY TO DRAWING.

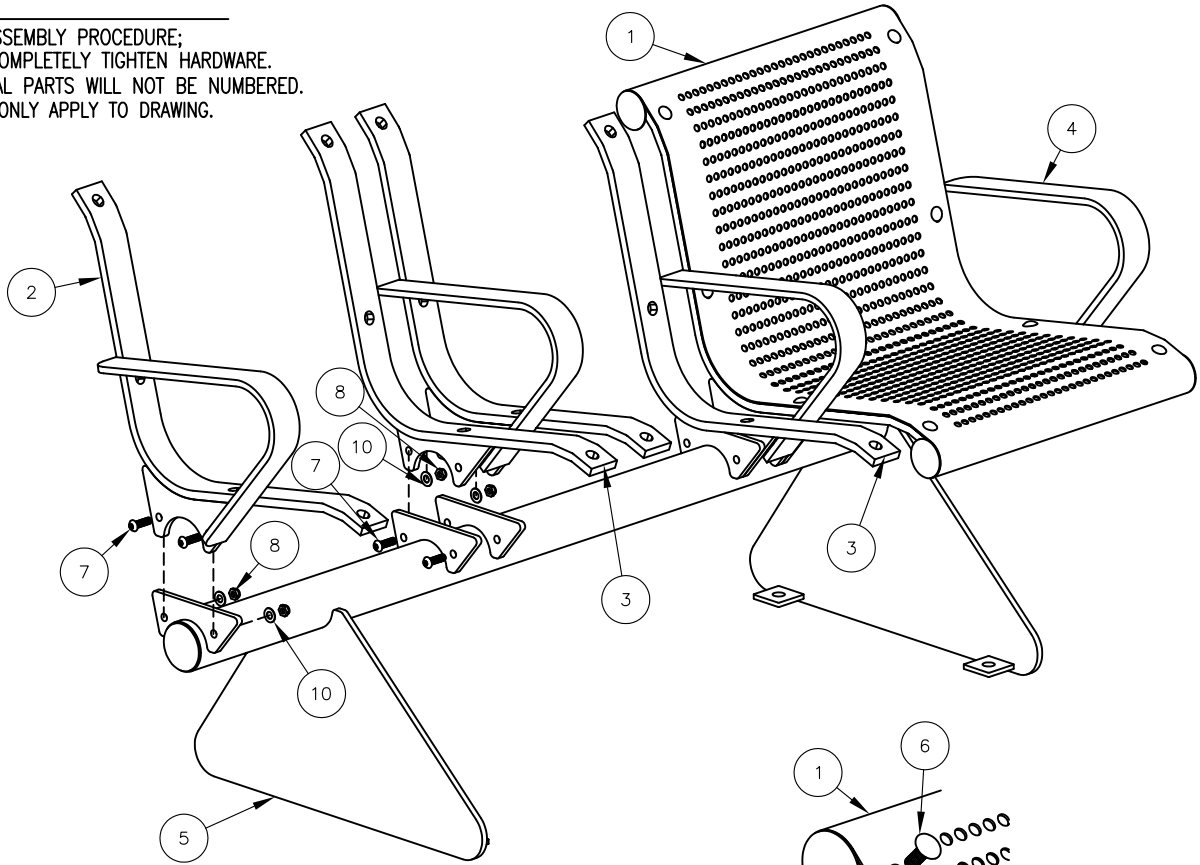

STEP 1:

- USE 1 - PC. THREE SEAT BASE FOR TRI-SUPPORT (5)
- 1 - PC. RIGHT SEAT STRAP W/ ARMREST (2)
- 1 - PC. LEFT SEAT STRAP W/ ARMREST (4)
- 4 - PCS. 3/8" X 1 1/4" SS. BTN. SKT. HD. CAP SCR. (7)
- 4 - PCS. 3/8" SS. THIN NYLON LOCKNUT (8)
- 8 - PCS. 3/8" SS. FLAT WASHER (10)

ATTACH RIGHT SEAT STRAP W/ ARMREST (2) & LEFT SEAT STRAP W/ ARMREST (4) TO THREE SEAT BASE FOR TRI-SUPPORT (5) USING HARDWARE (7, 8 & 10). TIGHTEN TO SNUG FIT.

STEP 2:

- USE 2 - PCS. CENTER SEAT STRAP W/ ARMREST (3)
- 8 - PCS. 3/8" X 1 1/4" SS. BTN. SKT. HD. CAP SCR. (7)
- 8 - PCS. 3/8" SS. NYLON LOCKNUT (8)
- 16 - PCS. 3/8" SS. FLAT WASHER (10)

ATTACH CENTER SEAT STRAP W/ ARMREST (3) TO STEP 1 ASSEMBLY USING HARDWARE (7, 8 & 10). TIGHTEN TO SNUG FIT.

STEP 3:

- USE 3 - PCS. ALL STL SEAT USING 14 GA. PERF. SH. (1)
- 24 - PCS. 3/8" X 1" SS. CGE. BOLT (6)
- 24 - PCS. 3/8" SS. HEX NUT (9)
- 24 - PCS. 3/8" SS. FLAT WASHER (10)

ATTACH ALL STL SEAT 14 GA. PERF. SH. (1) TO STEP 2 ASSEMBLY USING HARDWARE (6, 9 & 10). TIGHTEN TO SNUG FIT.

STEP 4:

UPON COMPLETION OF BENCH ASSEMBLY SQUARE ALL COMPONENTS THEN TIGHTEN ALL HARDWARE.

STEP 5:

MOUNT AND ANCHOR AS SPECIFIED.

ITEM	QTY	PART NO	DESCRIPTION
1	3	0-101-00-02	14 GA PERF STL SEAT
2	1	0-127-01	RIGHT SEAT STRAP W/ ARMREST
3	2	0-127-02	CENTER SEAT STRAP W/ ARMREST
4	1	0-127-03	LEFT SEAT STRAP W/ ARMREST
5	1	0-127-30-04/S-7	3 SEAT BASE FOR TRI-SUPPORT
6	24	1-11-028	3/8" X 1" SS CGE BOLT
7	12	1-12-111	3/8" X 1 1/4" SS BTN SKT HD CAP SCR
8	12	1-20-019	3/8" SS THIN NYLON LOCKNUT
9	24	1-21-007	3/8" SS HEX NUT
10	36	1-22-024	3/8" SS FLAT WASHER

DuMor, inc.
P.O. Box 142 Mifflintown, PA 17059-0142

SCALE : NONE
DATE DRAWN : 10/26/99
DRAWN BY : JSB
DATE REV. : 9/2/08
REV. BY : AWH

TITLE : BENCH ASSEMBLY
REV. F
DRAWING NUMBER 127-30/S-7