

**NOTES:**

- 1.) ALL ALUM & STL. MEMBERS COATED W/ ZINC RICH EPOXY THEN FINISHED W/ POLYESTER POWDER COATING.
- 2.) 1/2" x 3 3/4" EXPANSION ANCHOR BOLTS PROVIDED.

SLAT OPTIONS

- "CEDAR" RECYCLED PLASTIC
- "GREY" RECYCLED PLASTIC
- "REDWOOD" RECYCLED PLASTIC
- "WALNUT" RECYCLED PLASTIC
- OTHER \_\_\_\_\_

**NOTES:**

- 1.) DURING ASSEMBLY PROCEDURE;  
DO NOT COMPLETELY TIGHTEN HARDWARE.
- 2.) THE ACTUAL PARTS WILL NOT BE NUMBERED.  
NUMBERS ONLY APPLY TO DRAWING.
- 3.) UPON COMPLETION OF ASSEMBLY SQUARE  
ALL COMPONENTS THEN TIGHTEN ALL HARDWARE.
- 4.) MOUNT AND ANCHOR AS SPECIFIED.

**TOOLS REQ'D**

- 3/4" WRENCH
- 5/16" NUT DRIVER OR FLAT HEAD DRILL BIT
- 1/4" ALLEN WRENCH
- 1/2" MASONRY DRILL BIT
- DRILL

**PARTS LIST**

ITEM	QTY	PART NO	DESCRIPTION
1	5	0-505-60PL-05	2" X 3" X 71" INT'R SLAT, PL
2	2	0-505-60PL-06	2" X 4" X 71" EDGE SLAT, PL
3	2	0-507-00-02	CAST ALUM BKLS BENCH SUPPORT
4	1	0-507-60-03	6' STL BKLS SEAT FOR WOOD
5	4	1-12-111	3/8" X 1 1/4" SS BTN SKT HD CAP SCR
6	28	1-16-023	#14 X 7/8 SS HX WASH HD 'A' SLTD WD SCREW

**KITS PROVIDED**

ITEM	QTY	PART NO	DESCRIPTION
7	1	K-ANC0860-4	1/2" X 3 3/4" SS ANCHOR KIT (4PC)
8	1	K-BC0620-4	3/8" CAP SCR HARDWARE KIT (4 PC)
9	1	K-WS1414-28	#14 HEX HD WASH WOOD SCR ( 28PC )

① ATTACH SEAT TO CAST ALUM END SUPPORTS.

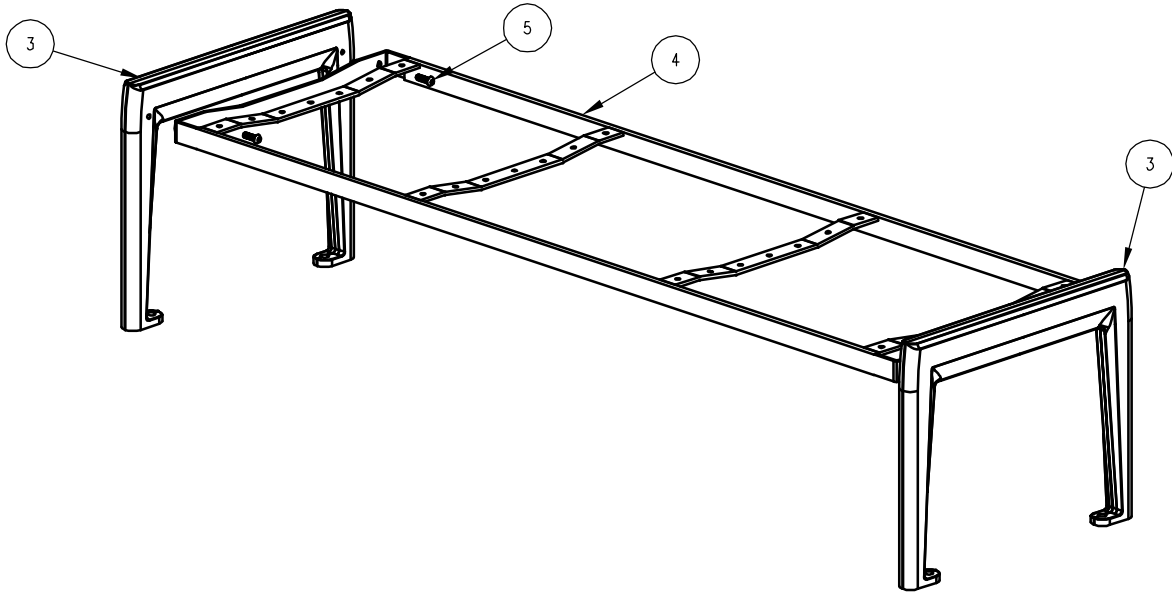

② ATTACH SLATS TO STEP 1.

