

NOTES:

- 1.) ALL ALUM & STL. MEMBERS COATED W/ ZINC RICH EPOXY THEN FINISHED W/ POLYESTER POWDER COATING.
- 2.) 1/2" X 3 3/4" EXPANSION ANCHOR BOLTS PROVIDED.

SLAT OPTIONS

- ANTIQUE MAHOGANY TEXTURED
- BRAZILIAN WALNUT TEXTURED
- OTHER _____

NOTES:

- 1.) DURING ASSEMBLY PROCEDURE;
DO NOT COMPLETELY TIGHTEN HARDWARE.
- 2.) THE ACTUAL PARTS WILL NOT BE NUMBERED.
NUMBERS ONLY APPLY TO DRAWING.
- 3.) UPON COMPLETION OF ASSEMBLY SQUARE
ALL COMPONENTS THEN TIGHTEN ALL HARDWARE.
- 4.) MOUNT AND ANCHOR AS SPECIFIED.

TOOLS REQ'D

- 3/4" WRENCH
- 5/16" NUT DRIVER OR FLAT HEAD DRILL BIT
- 3/16" ALLEN WRENCH
- 1/4" ALLEN WRENCH
- 1/2" MASONRY DRILL BIT
- DRILL

PARTS LIST

ITEM	QTY	PART NO	DESCRIPTION
1	1	0-505-60-01	6' STL BACKREST FOR WOOD
2	1	0-505-60-03	6' STL SEAT FOR WOOD
3	3	0-505-60TX-04	1" X 4" X 71" INT'R SLAT, TX
4	3	0-505-60TX-05	2" X 3" X 71" INT'R SLAT, TX
5	2	0-505-60TX-06	2" X 4" X 71" EDGE SLAT, TX
6	1	0-506-00-01L	CAST ALUM BENCH SUPPORT W/BACK, LEFT
7	1	0-506-00-01R	CAST ALUM BENCH SUPPORT W/BACK, RIGHT
8	4	1-12-105	5/16" X 1/2" SS BTN SKT HD CAP SCR
9	6	1-12-111	3/8" X 1 1/4" SS BTN SKT HD CAP SCR
10	32	1-16-023	#14 X 7/8 SS HX WASH HD 'A' SLTD WD SCREW

KITS PROVIDED

ITEM	QTY	PART NO	DESCRIPTION
11	1	K-ANC0860-4	1/2" X 3 3/4" SS ANCHOR KIT (4PC)
12	1	K-BC0508-4	5/16" CAP HARDWARE KIT (4PC)
13	1	K-BC0620-6	3/8" CAP SCR HARDWARE KIT (6 PC)
14	2	K-WS1414-16	#14 HEX HD WASH WOOD SCR (16PC)

① ATTACH SEAT TO CAST ALUM END SUPPORTS.

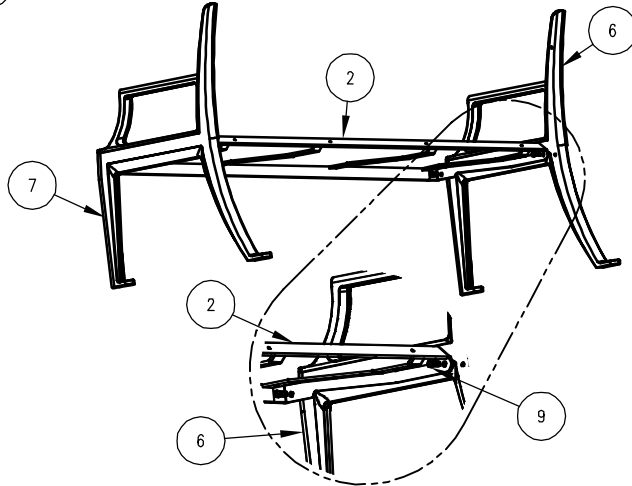

② ATTACH BACKREST TO CAST ALUM END SUPPORTS. ATTACH BACKREST TO SEAT AT FOUR TAPPED LOCATIONS.

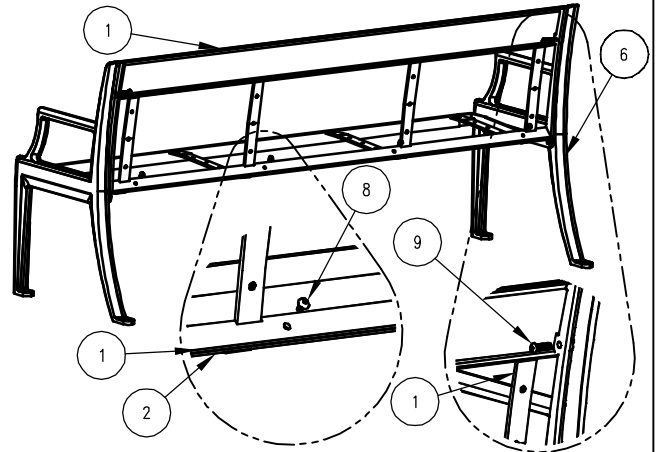

③ ATTACH SLATS TO STEP 2.

