

**NOTES:**

- 1.) ALL ALUM & STL. MEMBERS COATED W/ ZINC RICH EPOXY THEN FINISHED W/ POLYESTER POWDER COATING.
- 2.) 1/2" X 3 3/4" EXPANSION ANCHOR BOLTS PROVIDED.

**SLAT OPTIONS**

- ANTIQUE MAHOGANY TEXTURED
- BRAZILIAN WALNUT TEXTURED
- OTHER \_\_\_\_\_

**NOTES:**

- 1.) DURING ASSEMBLY PROCEDURE;  
DO NOT COMPLETELY TIGHTEN HARDWARE.
- 2.) THE ACTUAL PARTS WILL NOT BE NUMBERED.  
NUMBERS ONLY APPLY TO DRAWING.
- 3.) UPON COMPLETION OF ASSEMBLY SQUARE  
ALL COMPONENTS THEN TIGHTEN ALL HARDWARE.
- 4.) MOUNT AND ANCHOR AS SPECIFIED.

**TOOLS REQ'D**

- 3/4" WRENCH
- 5/16" NUT DRIVER OR FLAT HEAD DRILL BIT
- 3/16" ALLEN WRENCH
- 1/4" ALLEN WRENCH
- 1/2" MASONRY DRILL BIT
- DRILL

**PARTS LIST**

ITEM	QTY	PART NO	DESCRIPTION
1	1	0-505-00-01LNA	CAST ALUM BENCH SUPT W/BACK, NO ARM, LEFT
2	1	0-505-00-01RNA	CAST ALUM BENCH SUPT W/BACK, NO ARM, RIGHT
3	1	0-505-60-01	6' STL BACKREST FOR WOOD
4	1	0-505-60-03	6' STL SEAT FOR WOOD
5	3	0-505-60TX-04	1" X 4" X 71" INT'R SLAT, TX
6	3	0-505-60TX-05	2" X 3" X 71" INT'R SLAT, TX
7	2	0-505-60TX-06	2" X 4" X 71" EDGE SLAT, TX
8	4	1-12-105	5/16" X 1/2" SS BTN SKT HD CAP SCR
9	6	1-12-111	3/8" X 1 1/4" SS BTN SKT HD CAP SCR
10	32	1-16-023	#14 X 7/8 SS HX WASH HD 'A' SLTD WD SCREW

**KITS PROVIDED**

ITEM	QTY	PART NO	DESCRIPTION
11	1	K-ANC0860-4	1/2" X 3 3/4" SS ANCHOR KIT (4PC)
12	1	K-BC0508-4	5/16" CAP HARDWARE KIT (4PC)
13	1	K-BC0620-6	3/8" CAP SCR HARDWARE KIT (6 PC)
14	2	K-WS1414-16	#14 HEX HD WASH WOOD SCR ( 16PC )

① ATTACH SEAT TO CAST ALUM END SUPPORTS.

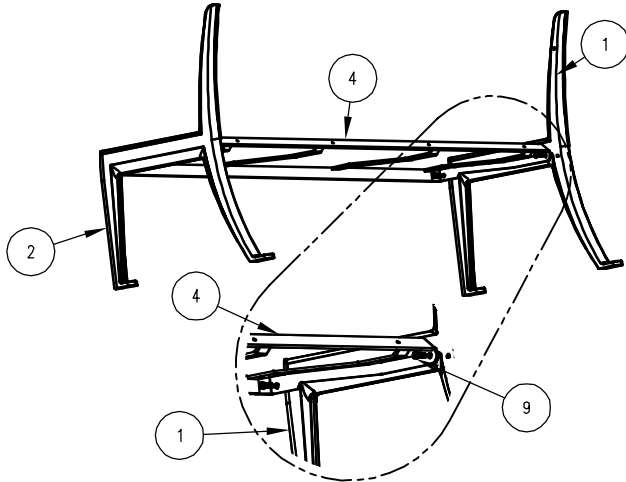

② ATTACH BACKREST TO CAST ALUM END SUPPORTS. ATTACH BACKREST TO SEAT AT FOUR TAPPED LOCATIONS.

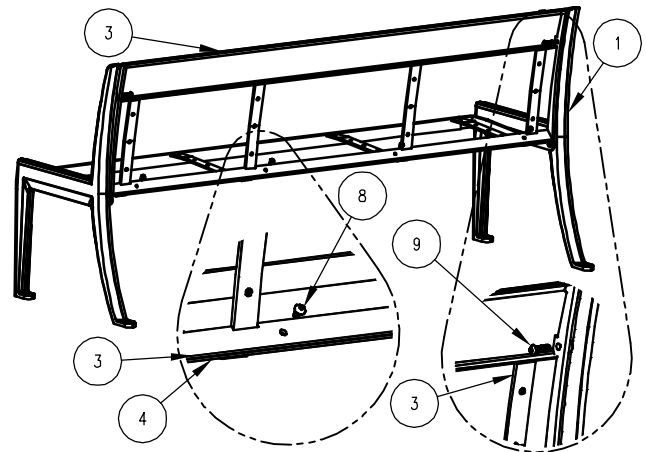

③ ATTACH SLATS TO STEP 2.

