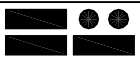

NOTES:

- 1.) ALL ALUM & STL. MEMBERS COATED W/ ZINC RICH EPOXY THEN FINISHED W/ POLYESTER POWDER COATING.
- 2.) 1/2" X 3 3/4" EXPANSION ANCHOR BOLTS PROVIDED.

 DuMor, inc.	BENCH	DATE DRAWN : 10/15/19	REV. A	DRAWING NUMBER 505-60HC	SHEET 1 OF 2
		DRAWN BY : RDH			
		DATE REV. :			
		REV. BY :			

PARTS LIST

ITEM	QTY	PART NO	DESCRIPTION
1	1	0-505-00-01L	CAST ALUM BENCH SUPPORT W/BACK, LEFT
2	1	0-505-00-01R	CAST ALUM BENCH SUPPORT W/BACK, RIGHT
3	1	0-505-60HC-03	6' STL SEAT, HORIZ CHANNEL
4	1	0-505-60HC-05	6' STL BACKREST, HORIZ CHANNEL
5	4	1-12-105	5/16" X 1/2" SS BTN SKT HD CAP SCR
6	6	1-12-111	3/8" X 1 1/4" SS BTN SKT HD CAP SCR

KITS PROVIDED

ITEM	QTY	PART NO	DESCRIPTION
7	1	K-ANCO860-4	1/2" X 3 3/4" SS ANCHOR KIT (4PC)
8	1	K-BC0508-4	5/16" CAP HARDWARE KIT (4PC)
9	1	K-BC0620-6	3/8" CAP SCR HARDWARE KIT (6 PC)

NOTES:

- 1.) DURING ASSEMBLY PROCEDURE;
DO NOT COMPLETELY TIGHTEN HARDWARE.
- 2.) THE ACTUAL PARTS WILL NOT BE NUMBERED.
NUMBERS ONLY APPLY TO DRAWING.
- 3.) UPON COMPLETION OF ASSEMBLY SQUARE
ALL COMPONENTS THEN TIGHTEN ALL HARDWARE.
- 4.) MOUNT AND ANCHOR AS SPECIFIED.

TOOLS REQ'D

- 3/4" WRENCH
- 3/16" ALLEN WRENCH
- 1/4" ALLEN WRENCH
- 1/2" MASONRY DRILL BIT
- DRILL

① ATTACH SEAT TO CAST ALUM END SUPPORTS. DO NOT TIGHTEN HARDWARE COMPLETELY.

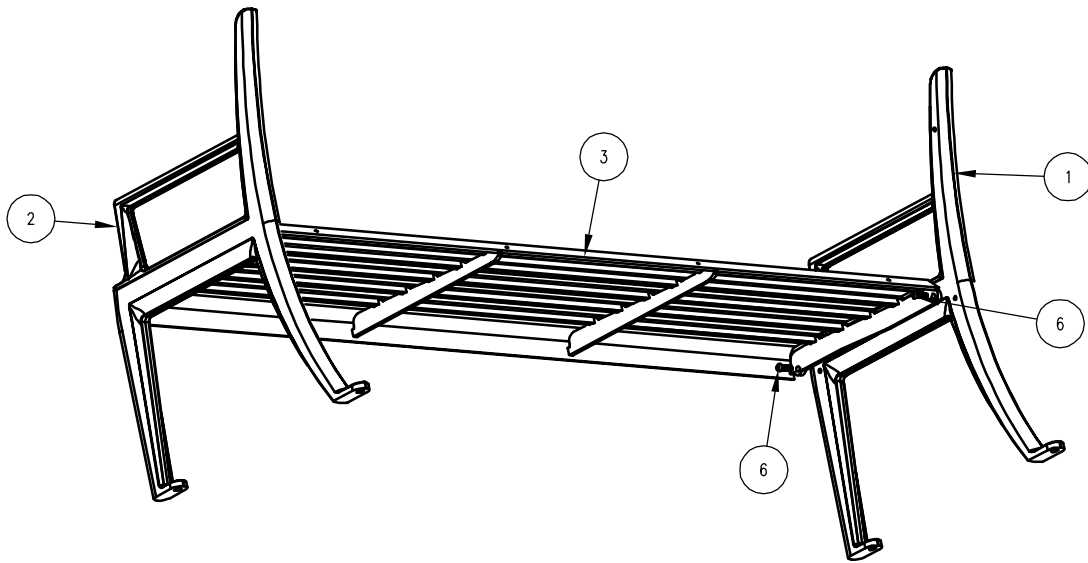

② ATTACH BACKREST TO CAST ALUM END SUPPORTS. ATTACH BACKREST TO SEAT AT FOUR TAPPED LOCATIONS. TIGHTEN ALL HARDWARE INCLUDING HARDWARE IN STEP 1.

