

S-2 SURFACE MOUNT

SLAT OPTIONS

- ANTIQUE MAHOGANY TEXTURED
- BRAZILIAN WALNUT TEXTURED
- OTHER \_\_\_\_\_

NOTES:

- 1.) ALL STL. MEMBERS COATED W/ ZINC RICH EPOXY THEN FINISHED W/ POLYESTER POWDER COATING.
- 2.) 1/2" X 3 3/4" EXPANSION ANCHOR BOLTS PROVIDED FOR S-2 OPTION.

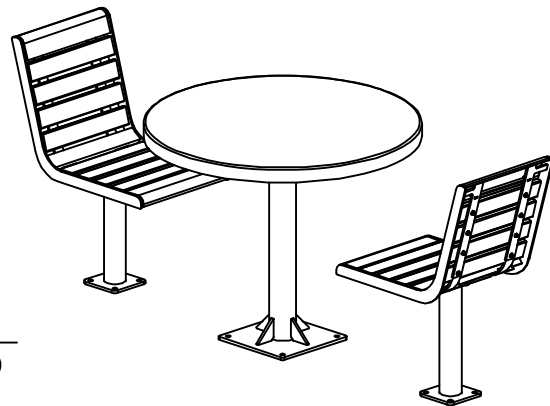

TABLE

DATE DRAWN : 11/07/18  
 DRAWN BY : ESS  
 DATE REV. :  
 REV. BY :

REV.  
A

DRAWING NUMBER

296-36-20TX

SHEET  
1 OF 2

**NOTES:**

- 1.) DURING ASSEMBLY PROCEDURE;  
DO NOT COMPLETELY TIGHTEN HARDWARE.
- 2.) THE ACTUAL PARTS WILL NOT BE NUMBERED.  
NUMBERS ONLY APPLY TO DRAWING.
- 3.) UPON COMPLETION OF ASSEMBLY SQUARE  
ALL COMPONENTS THEN TIGHTEN ALL HARDWARE.
- 4.) MOUNT AND ANCHOR AS SPECIFIED.

**TOOLS REQ'D**

- 3/4" WRENCH
- 1/4" WRENCH
- 1/2" MASONRY DRILL BIT  
DRILL

**PARTS LIST FOR S-2**

ITEM	QTY	PART NO	DESCRIPTION
1	2	0-294-00-03	STL SEAT FRAME FOR WOOD - ALL WELDED
2	16	0-294-00TX-04	15 1/4" SEAT SLAT, TX
3	1	0-296-00-01/S-2	TABLE SUPT FRAME FOR SURFACE MT
4	2	0-296-00-02/S-2	STL PEDESTAL SEAT SUPPORT, PLATES
5	1	0-296-36-03	36" DIA STL TABLE TOP
6	8	1-11-042	1/2" X 1 1/2" SS CGE BOLT
7	32	1-16-023	#14 X 7/8 SS HX WASH HD 'A' SLTD WD SCREW
8	8	1-20-015	1/2" SS NYLON LOCKNUT
9	8	1-22-015	1/2" SS FLAT WASHER

**KITS PROVIDED FOR S-2**

ITEM	QTY	PART NO	DESCRIPTION
10	3	K-ANCO860-4	1/2" X 3 3/4" SS ANCHOR KIT (4PC)
11	2	K-CG0824-4L	1/2" CGE BOLT HARDWARE KIT (4)
12	2	K-WS1414-16	#14 HEX HD WASH WOOD SCR ( 16PC )

**1 ATTACH TABLE TOP TO TABLE SUPPORT.**

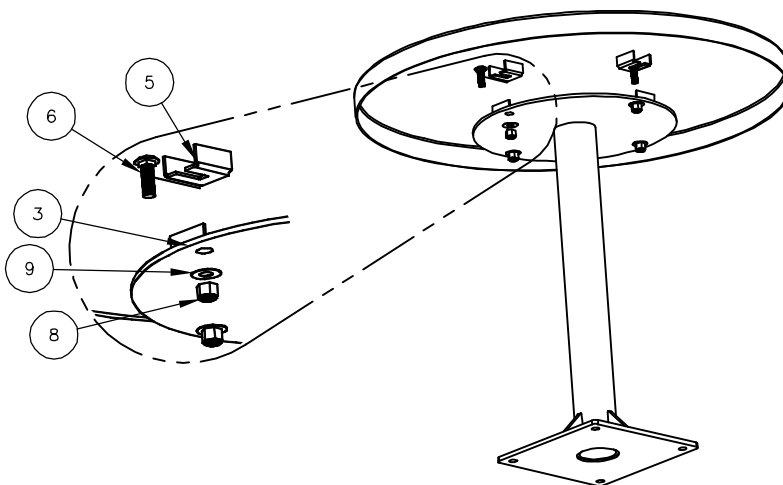

**2 ATTACH STL. SEAT FRAME TO SEAT SUPPORT.**

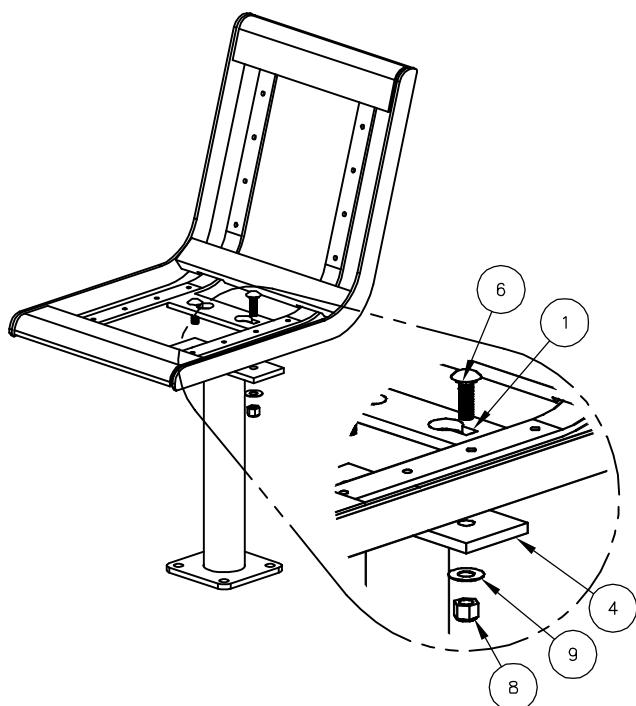

**3 ATTACH SLATS TO STEP #2.**

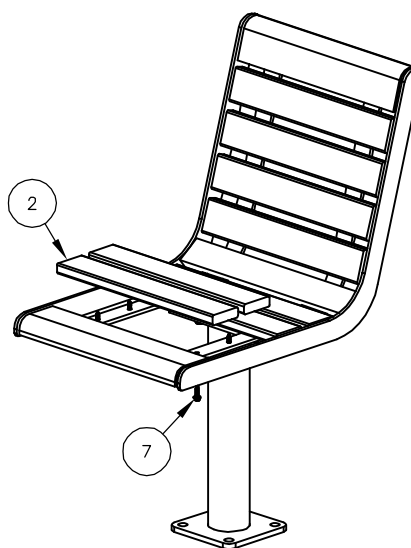

NOTE:  
IF DESIRED, USE SUPPLIED TOUCH UP PAINT  
TO COAT VISIBLE WOOD FASTENER HEADS.