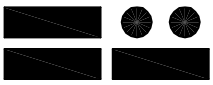

NOTES:

- 1.) ALL STL. MEMBERS COATED W/ ZINC RICH EPOXY THEN FINISHED W/ POLYESTER POWDER COATING.
- 2.) $1/2" \times 3 \frac{3}{4}"$ EXPANSION ANCHOR BOLTS PROVIDED.

LENGTH OPTIONS

- 6' BENCH
- 8' BENCH

 DuMor, inc. P.O. Box 142 Mifflintown, PA 17059-0142	SCALE :	NONE	TITLE :		BENCH	
	DATE DRAWN :	9/30/97	REV.	DRAWING NUMBER	119 SERIES	SHEET 1 OF 2
	DRAWN BY :	AH	E			
	DATE REV. :	12/19/06				
REV. BY :	AWH					

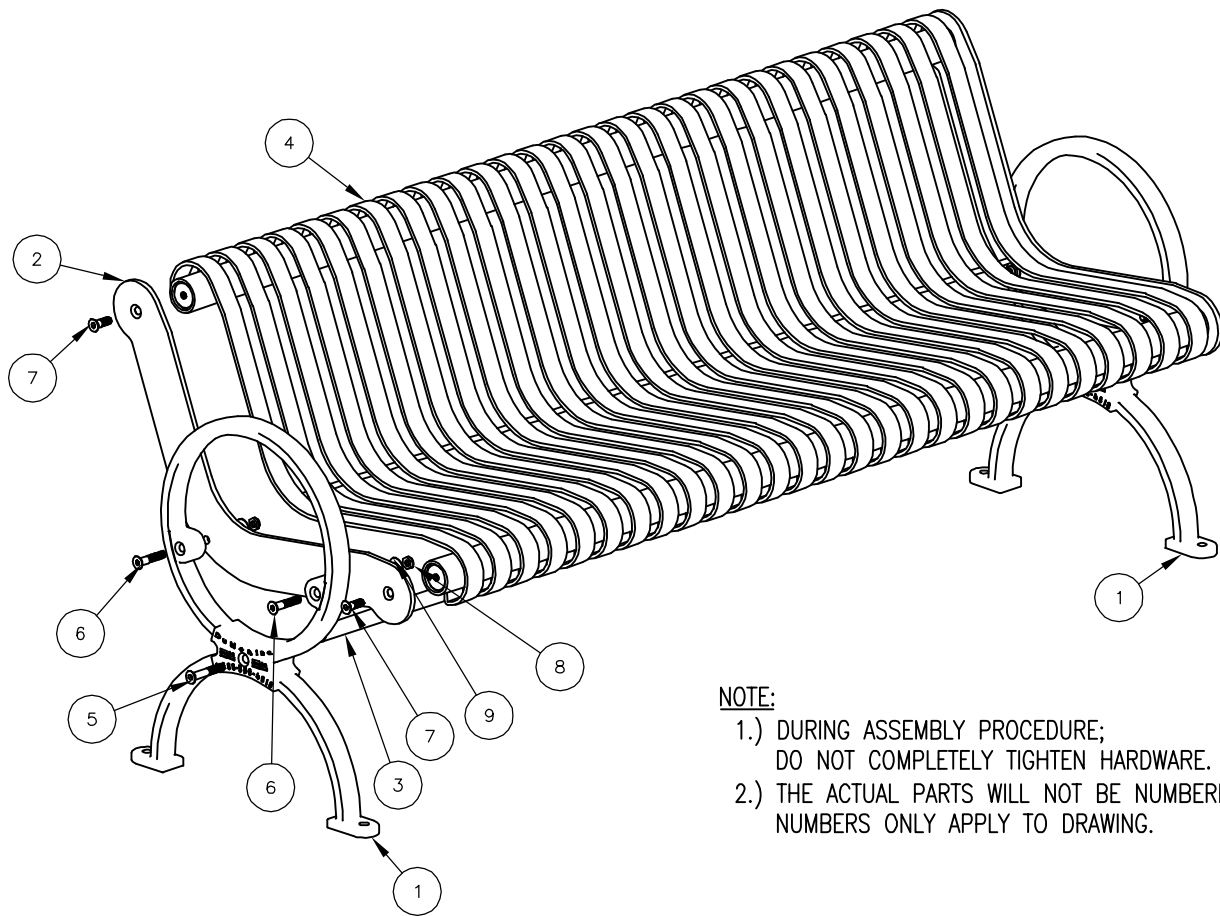

NOTE:

- 1.) DURING ASSEMBLY PROCEDURE;
DO NOT COMPLETELY TIGHTEN HARDWARE.
- 2.) THE ACTUAL PARTS WILL NOT BE NUMBERED:
NUMBERS ONLY APPLY TO DRAWING.

STEP 1:

USE 1 - PC. 6' ALL STL. SEAT ASSEMBLY (4)
 2 - PCS. SEAT END PLATE (2)
 4 - PCS. 1/2" X 1 1/2" FLT. SKT. HD. CAP SCR. (7)
 ATTACH SEAT END PLATE (2) TO 6' ALL STL. SEAT ASSEMBLY
 (4) USING HARDWARE (7) TIGHTEN TO SNUG FIT.

STEP 4:

UPON COMPLETION OF BENCH ASSEMBLY SQUARE
 ALL COMPONENTS THEN TIGHTEN ALL HARDWARE.

STEP 2:

USE 2 - PC. CAST IRON END SUPPORT (1)
 4 - PC. 1/2" X 2 1/2" SS. FLT. SKT. HD. CAP SCR. (6)
 4 - PC. 1/2" SS. THIN NYLON LOCK NUT (8)
 4 - PC. 1/2" SS. FLAT WASHER (9)
 ATTACH CAST IRON END SUPPORT (1) TO STEP 1 ASSEMBLY
 USING HARDWARE (6, 8, & 9). TIGHTEN TO SNUG FIT.

STEP 5:

MOUNT AND ANCHOR AS SPECIFIED.

STEP 3:

USE 1 - PC. 71 3/4" PIPE BRACE (3)
 2 - PCS. 1/2" X 3" FLT. SKT. HD. CAP SCR. (5)
 ATTACH 71 3/4" PIPE BRACE (3) TO STEP 2 ASSEMBLY
 USING HARDWARE (5). TIGHTEN TO SNUG FIT.

ITEM	QTY	PART NO	DESCRIPTION
1	2	0-119-00-01	CAST IRON SUPPORT
2	2	0-119-00-02	SEAT END PLATE
3	1	0-57-60-04	71 3/4" PIPE BRACE
4	1	0-58-60-01	6' STL SEAT
5	2	1-12-037	1/2" X 3" SS FLT SKT HD CAP SCR
6	4	1-12-065	1/2" X 2 1/2" FLT SKT HD CAP SCR
7	4	1-12-074	1/2" X 1 1/2" SS FLT SKT HD CAP
8	4	1-20-018	1/2" SS THIN NYLON LOCKNUT
9	4	1-22-015	1/2" SS FLAT WASHER

DuMor, inc.
 P.O. Box 142 Mifflintown, PA 17059-0142

SCALE : NONE
 DATE DRAWN : 9/30/97
 DRAWN BY : AH
 DATE REV. : 12/19/06
 REV. BY : AWH

TITLE : BENCH ASSEMBLY

REV. E DRAWING NUMBER 119 SERIES

SHEET 2 OF 2