

LENGTH OPTIONS

- 6' BENCH
- 8' BENCH

NOTES

- 1.) ALL STL. MEMBERS COATED W/ ZINC RICH EPOXY THEN POLYESTER POWDER COATED.
- 2.) WOOD MEMBERS TRTD. W/ CLEAR PRESERVATIVE.
- 3.) 1/2" X 3 3/4" EXPANSION ANCHOR BOLTS PROVIDED.

WOOD OPTIONS

- 'C' & BTR. DOUGLAS FIR S4S EE
- IPE S4S EE
- OTHER _____

DuMor, inc.
 P.O. Box 142 Mifflintown, PA 17059-0142

SCALE : NONE
 DATE DRAWN : 10/18/98
 DRAWN BY : AH
 DATE REV. : 10/27/11
 REV. BY : RDH

TITLE : BENCH

REV. D

DRAWING NUMBER

91 SERIES

SHEET 1 OF 2

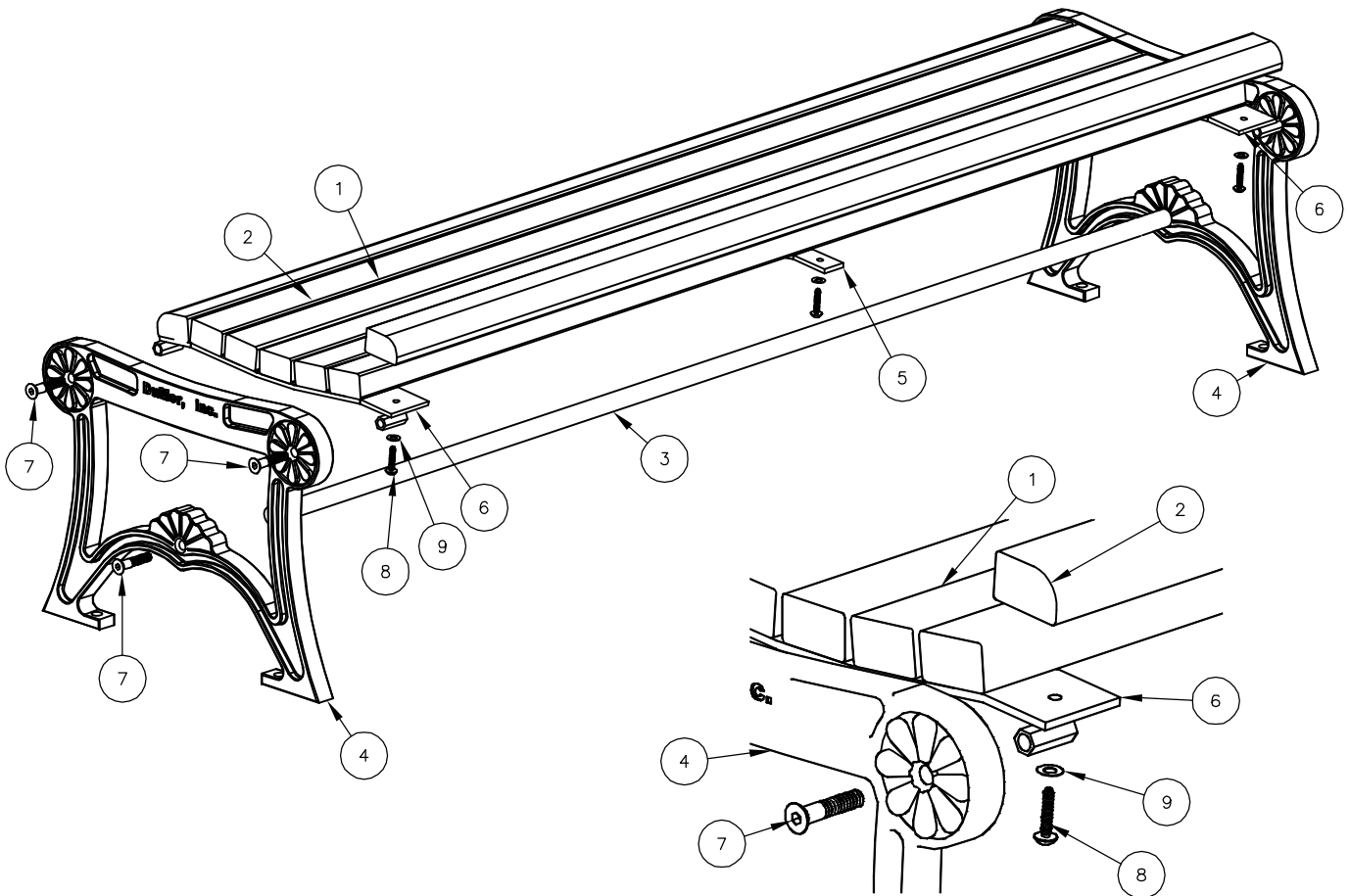

NOTE:

- 1.) DURING ASSEMBLY PROCEDURE;
DO NOT COMPLETELY TIGHTEN HARDWARE.
- 2.) THE ACTUAL PARTS WILL NOT BE NUMBERED;
NUMBERS ONLY APPLY TO DRAWING.

STEP 1:

- USE 2 - PCS. CAST IRON BENCH SUPPORT (4)
 - 1 - PC. 71 3/4" PIPE BRACE (3)
 - 2 - PCS. 1/2" X 2 1/2" FLT. SKT. HD. CAP SCR. (7)
- ATTACH CAST IRON BENCH SUPPORTS (4) TO 71 3/4" PIPE BRACE (3) USING HARDWARE (7). TIGHTEN TO SNUG FIT.

STEP 2:

- USE 2 - PCS. END STRAP (6)
 - 4 - PCS. 1/2" X 2 1/2" FLT. SKT. HD. CAP SCR. (7)
- ATTACH END STRAP (6) TO STEP 1 ASSEMBLY USING HARDWARE (7). TIGHTEN TO SNUG FIT.

STEP 3:

- USE 5 - PCS. 2" X 3" X 71" WOOD INT'R SLAT (1)
 - 2 - PCS. 2" X 3" X 71" WOOD EDGE SLAT (2)
 - 14 - PCS. 5/16" X 1 1/2" SS. BTN. SKT. HD. LAG (8)
 - 14 - PCS. 5/16" SS. FLAT WASHER (9)
- ATTACH INT'R SLATS (1) & EDGE SLATS (2) TO STEP 2 ASSEMBLY USING HARDWARE (8 & 9). TIGHTEN TO SNUG FIT. REPEAT UNTIL ALL SLATS ARE ATTACHED.

DETAIL A

STEP 4:

- USE 1 - PC. CENTER STRAP (5)
 - 7 - PCS. 5/16" X 1 1/2" SS. BTN. SKT. HD. LAG (8)
 - 7 - PCS. 5/16" SS. FLAT WASHER (9)
- ATTACH CENTER STRAP (5) TO STEP 3 ASSEMBLY USING HARDWARE (8 & 9). TIGHTEN TO SNUG FIT.

STEP 5:

UPON COMPLETION OF BENCH ASSEMBLY SQUARE ALL COMPONENTS THEN TIGHTEN ALL HARDWARE.

STEP 6:

MOUNT AND ANCHOR AS SPECIFIED.

ITEM	QTY	PART NO	DESCRIPTION
1	5	0-57-60-01	2" X 3" X 71" WOOD INT'R SLAT
2	2	0-57-60-02	2" X 3" X 71" WOOD EDGE SLAT
3	1	0-57-60-04	71 3/4" PIPE BRACE
4	2	0-91-00-02	BKLESS CAST IRON BNCH SUPT
5	1	0-91-00-03	CENTER STRAP
6	2	0-91-00-04	END CONTOUR STRAP
7	6	1-12-065	1/2" X 2 1/2" FLT SKT HD CAP SCR
8	21	1-13-023	5/16" X 1 1/2" SS BTN SKT HD LAG
9	21	1-22-017	5/16" SS FLAT WASHER

DuMor, inc.
P.O. Box 142 Mifflintown, PA 17059-0142

SCALE : NONE
DATE DRAWN : 10/18/98
DRAWN BY : AH
DATE REV. : 10/27/11
REV. BY : RDH

TITLE : BENCH ASSEMBLY

REV. D

DRAWING NUMBER

91 SERIES

SHEET 2 OF 2