

S-2 SURFACE

S-5 FREE STANDING

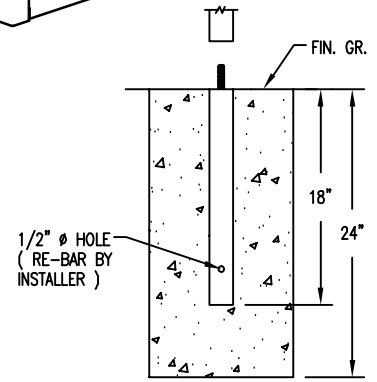

□ S-1 EMBEDMENT

NOTES:

- 1.) ALL STL. MEMBERS COATED W/ ZINC RICH EPOXY THEN FINISHED W/ POLYESTER POWDER COATING.
- 2.) 1/2" X 3 3/4" EXPANSION ANCHOR BOLTS PROVIDED FOR S-2.



TABLE

DATE DRAWN : 11/20/17
 DRAWN BY : RDH
 DATE REV. :
 REV. BY :

REV. A

DRAWING NUMBER

299-60HS

SHEET 1 OF 2

NOTES:

- 1.) DURING ASSEMBLY PROCEDURE;
DO NOT COMPLETELY TIGHTEN HARDWARE.
- 2.) THE ACTUAL PARTS WILL NOT BE NUMBERED.
NUMBERS ONLY APPLY TO DRAWING.
- 3.) UPON COMPLETION OF ASSEMBLY SQUARE
ALL COMPONENTS THEN TIGHTEN ALL HARDWARE.
- 4.) MOUNT AND ANCHOR AS SPECIFIED.

TOOLS REQ'D

- 3/4" WRENCH
- 5/16" ALLEN WRENCH
- 1/2" MASONRY DRILL BIT
- DRILL

PARTS LIST FOR S-2

ITEM	QTY	PART NO	DESCRIPTION
1	1	0-298-60HS-03	6' STL TABLE TOP
2	2	0-298-60HS-04	6' STL SEAT
3	2	0-299-00-01	STL TABLE END SUPPORT
4	4	0-299-00-02	STL SEAT END SUPPORT
5	2	0-299-00-06	STL TABLE BRACE
6	1	0-299-60-03	6' STL TABLE SUB FRAME
7	2	0-299-60-04	6' STL SEAT SUB FRAME
8	12	0-94-00-02/S-2	SURFACE MOUNT FOOT PAD, PC
9	16	1-11-042	1/2" X 1 1/2" SS CGE BOLT
10	12	1-12-014	1/2" X 1" SS FLT SKT HD CAP SCR
11	2	1-12-030	1/2" X 1 1/2" SS BTN SKT HD CAP SCR
12	16	1-20-015	1/2" SS NYLON LOCKNUT
13	16	1-22-015	1/2" SS FLAT WASHER

KITS PROVIDED FOR S-2

ITEM	QTY	PART NO	DESCRIPTION
14	3	K-ANC0860-4	1/2" X 3 3/4" SS ANCHOR KIT (4PC)
15	1	K-BC0824-2	1/2" CAP HARDWARE KIT (2PC)
16	4	K-CG0824-4L	1/2" CGE BOLT HARDWARE KIT (4)
17	3	K-FC0816-4	1/2" CAP HARDWARE KIT (4 PCS)

1 ATTACH SUB FRAME TO END SUPPORTS.

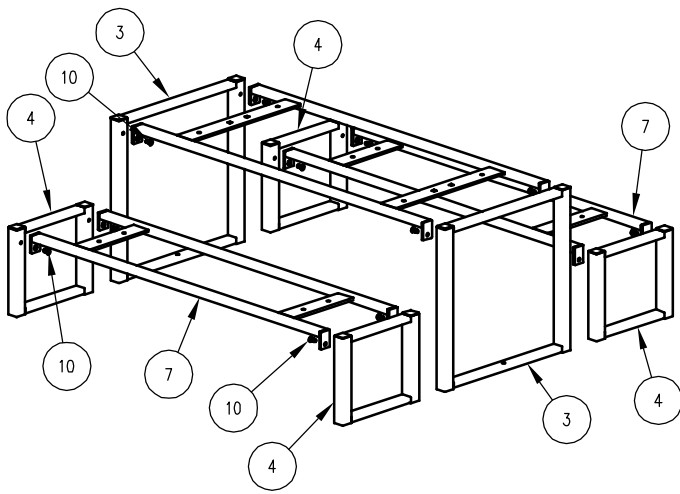

2 ATTACH TABLE BRACES TO STEP 1.

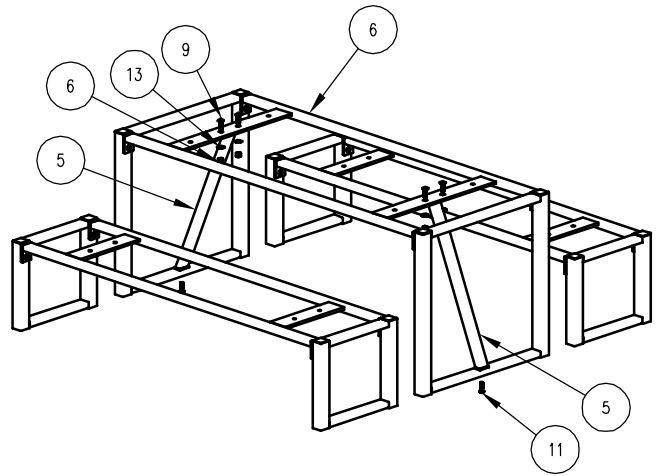

3 ATTACH STEEL TABLE TOP & SEAT TO STEP 2.

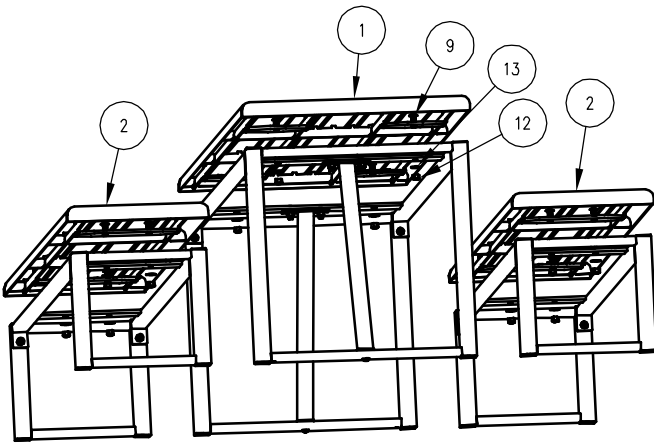

4 ATTACH SURFACE MOUNT FOOT PADS TO STEP 3.

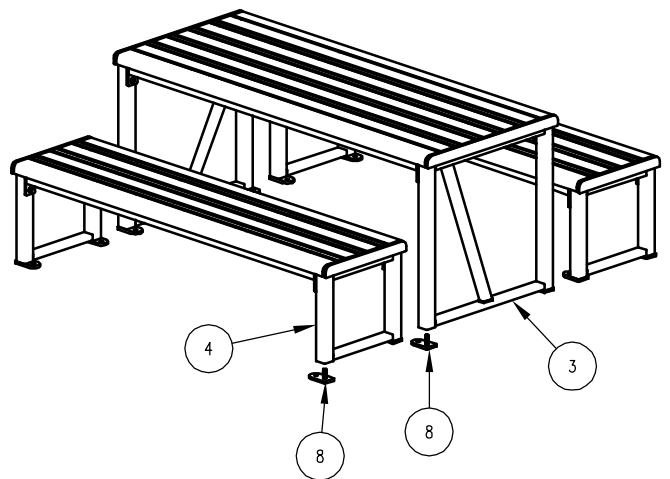

ASSEMBLY INSTRUCTIONS

DATE DRAWN : 11/20/17
 DRAWN BY : RDH
 DATE REV. :
 REV. BY :

REV. A

DRAWING NUMBER

299-60HS

SHEET 2 OF 2