

NOTES

- 1.) ALL STL. MEMBERS COATED W/ ZINC RICH EPOXY THEN FINISHED W/ POLYESTER POWDER COATING.
- 2.) 1/2" X 3 3/4" EXPANSION ANCHOR BOLTS PROVIDED.

SLAT OPTIONS

- "CEDAR" RECYCLED PLASTIC
- "GREY" RECYCLED PLASTIC
- "REDWOOD" RECYCLED PLASTIC
- "WALNUT" RECYCLED PLASTIC
- OTHER _____

DuMor, inc.
P.O. Box 142 Mifflintown, PA 17059-0142

SCALE :	NONE
DATE DRAWN :	10/16/09
DRAWN BY :	AWH
DATE REV. :	10/26/11
REV. BY :	JSB

TITLE :		BENCH	
REV.	DRAWING NUMBER	186-60PL	SHEET 1 OF 2
B			

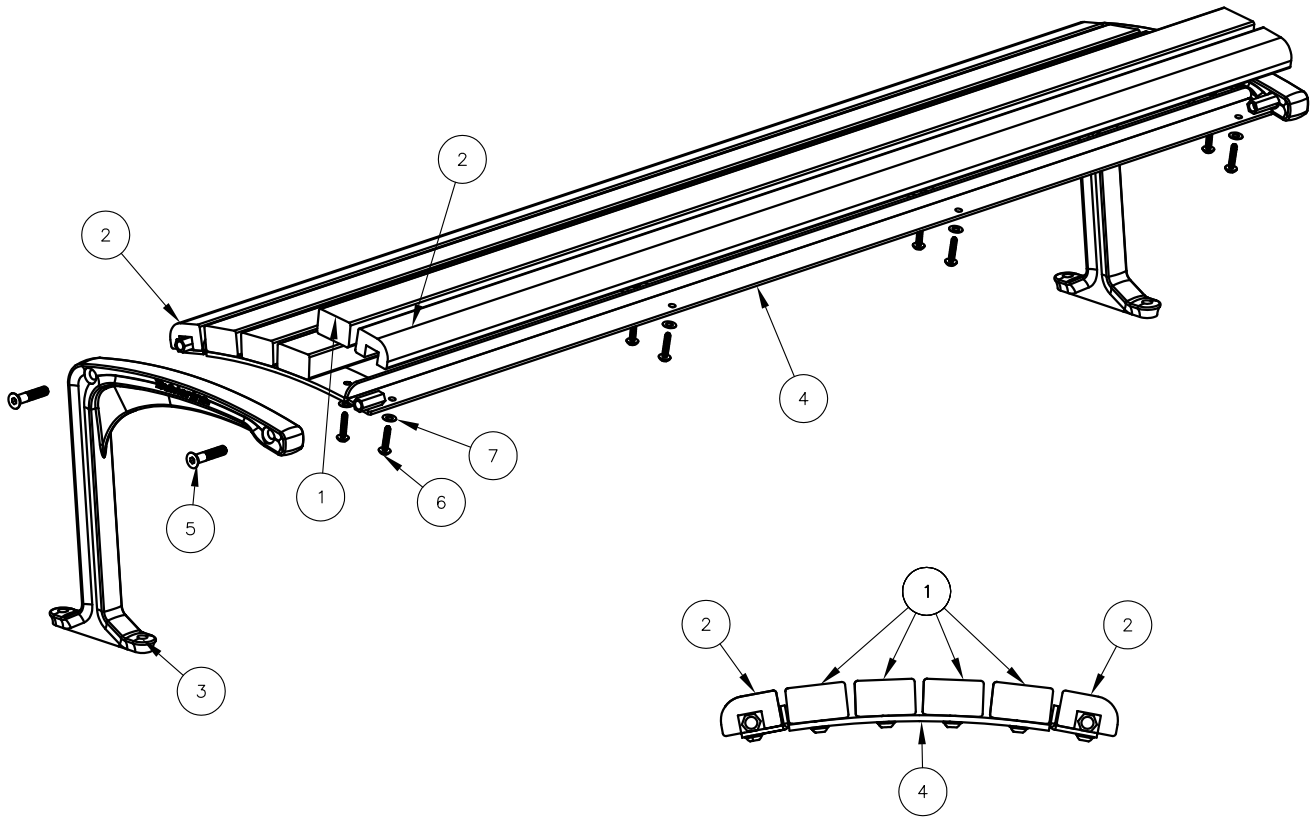

STEP 1:

- USE 4 - PCS. 2" X 3" X 71" PLASTIC SLAT (1)
 - 2 - PCS. 71" PLASTIC EDGE SLAT (2)
 - 1 - PC. 6' SEAT FRAME (4)
 - 24 - PCS. 5/16" X 1 1/2" SS. BTN. SKT. HD. LAG (6)
 - 24 - PCS. 5/16" SS. FLAT WASHER (7)
- ATTACH PLASTIC SLATS (1 & 2) TO 6' SEAT FRAME (4) USING HARDWARE (6 & 7). TIGHTEN TO SNUG FIT.

NOTE:

- 1.) DURING ASSEMBLY PROCEDURE; DO NOT COMPLETELY TIGHTEN HARDWARE.
- 2.) THE ACTUAL PARTS WILL NOT BE NUMBERED: NUMBERS ONLY APPLY TO DRAWING.

STEP 2:

- USE 2 - PCS. BKLS BENCH SUPPORT (3)
 - 4 - PCS. 1/2" X 2 1/2" FLT. SKT. HD. CAP SCR. (5)
- ATTACH BKLS BENCH SUPT (3) TO STEP 1 ASSEMBLY USING HARDWARE (5). TIGHTEN TO SNUG FIT.

STEP 3:

UPON COMPLETION OF BENCH ASSEMBLY SQUARE ALL COMPONENTS THEN TIGHTEN ALL HARDWARE.

STEP 4:

MOUNT AND ANCHOR AS SPECIFIED.

ITEM	QTY	PART NO	DESCRIPTION
1	4	0-143-60PL-01	2" X 3" X 71" PLASTIC INT'R SLAT
2	2	0-185-60PL-05	71" EDGE SLAT, PLASTIC
3	2	0-186-00-01	BKLS BENCH SUPT
4	1	0-186-60-02	6' BKLS BENCH FRAME
5	4	1-12-065	1/2" X 2 1/2" FLT SKT HD CAP SCR
6	24	1-13-023	5/16" X 1 1/2" SS BTN SKT HD LAG
7	24	1-22-017	5/16" SS FLAT WASHER

 DuMor, inc. P.O. Box 142 Mifflintown, PA 17059-0142	SCALE :	NONE		
	DATE DRAWN :	10/16/09		
	DRAWN BY :	AWH		
	DATE REV. :			
REV. BY :		TITLE :	BENCH ASSEMBLY	
	REV. A	DRAWING NUMBER	186-60-PL	SHEET 2 OF 2