

10"  $\phi$  OPENING

3/8" THK. STL. COVER PLATE

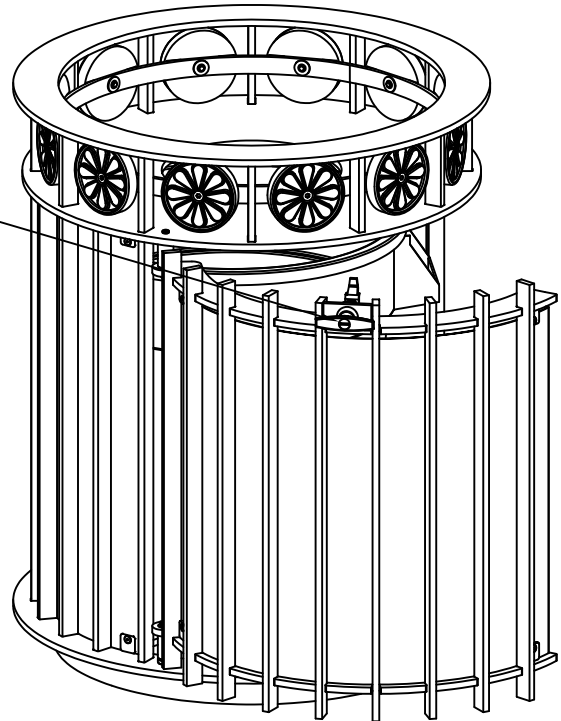

LATCHING DEVICE

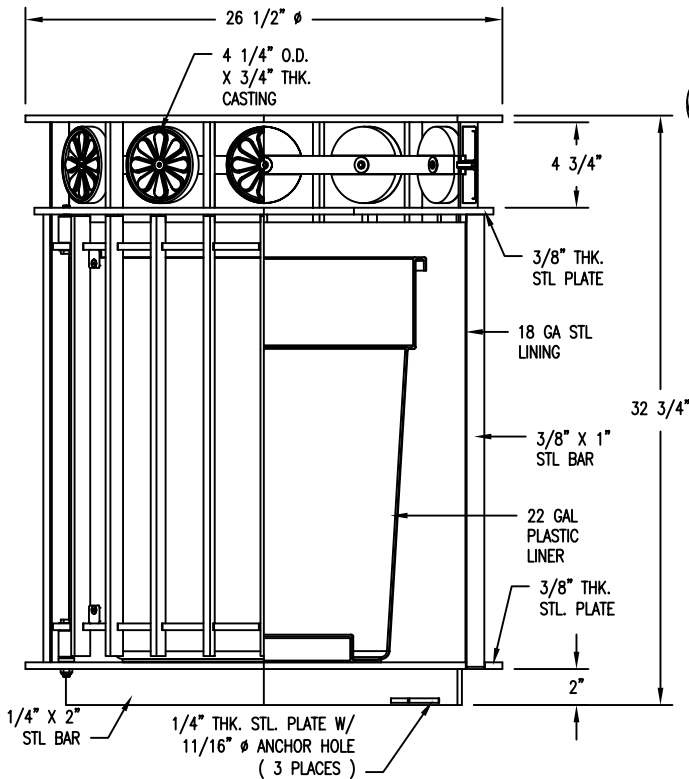

26 1/2"  $\phi$

4 1/4" O.D. X 3/4" THK. CASTING

4 3/4"

3/8" THK. STL. PLATE

18 GA STL LINING

3/8" X 1" STL BAR

22 GAL PLASTIC LINER

3/8" THK. STL. PLATE

32 3/4"

1/4" X 2" STL BAR

1/4" THK. STL. PLATE W/ 11/16"  $\phi$  ANCHOR HOLE ( 3 PLACES )

2"

**NOTES:**

- 1.) ALL STL. MEMBERS COATED W/ ZINC RICH EPOXY THEN FINISHED W/ POLYESTER POWDER COATING.
- 2.) 1/2" X 3 3/4" EXPANSION ANCHOR BOLTS PROVIDED.
- 3.) SIDE OF RECEPTACLE HINGES OPEN FOR REMOVAL OF LINER.
- 4.) LATCH PROVIDED W/ KEY, USE OF KEY OPTIONAL.
- 5.) RECEPTACLE FULLY ASSEMBLED AT FACTORY.



**DuMor, inc.**

P.O. Box 142 Mifflintown, PA 17059-0142

SCALE : NONE

DATE DRAWN : 12/4/00

DRAWN BY : AWH

DATE REV. : 12/17/09

REV. BY : AWH

TITLE :

RECEPTACLE

REV.

G

DRAWING NUMBER

102-22SH-FTO

SHEET

1 OF 2

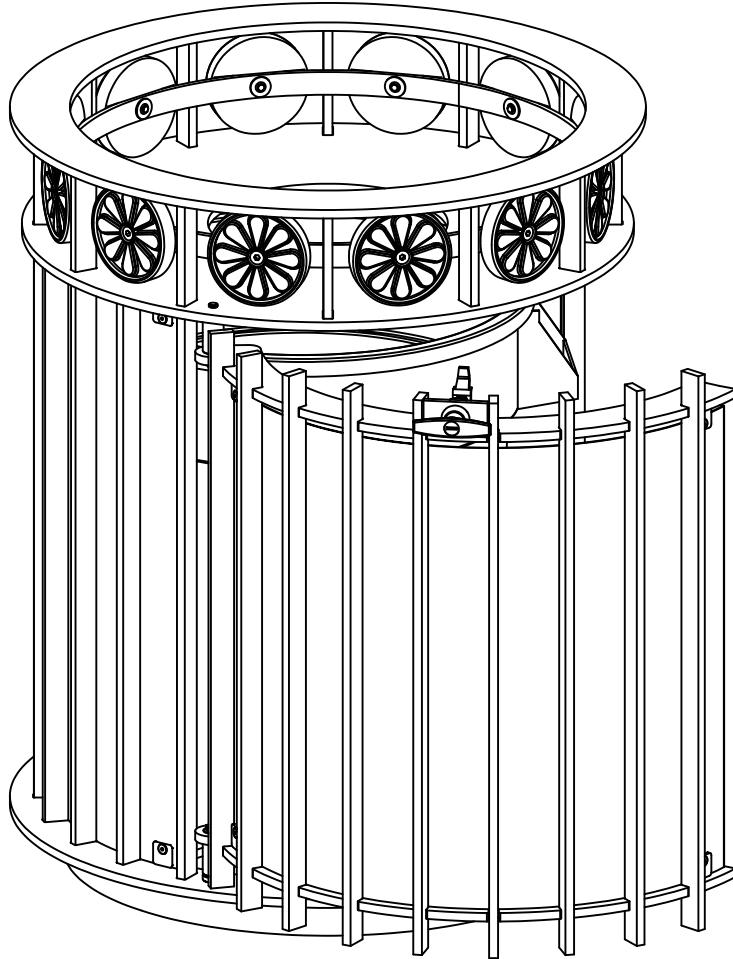

NOTE:

- 1.) RECEPTACLE SHIPPED FULLY ASSEMBLED.
- 2.) MOUNT AND ANCHOR AS SPECIFIED.



DuMor, inc.

P.O. Box 142 Mifflintown, PA 17059-0142

SCALE :	NONE
DATE DRAWN :	12/4/00
DRAWN BY :	AWH
DATE REV. :	12/17/09
REV. BY :	AWH

TITLE :	RECEPTACLE ASSEMBLY	
REV.	DRAWING NUMBER	
G	102-22SH-FTO	
		SHEET 2 OF 2