

- NOTES:
- 1.) ALL STL. MEMBERS COATED W/ ZINC RICH EPOXY THEN FINISHED W/ POLYESTER POWDER COATING.
 - 2.) 1/2" X 3 3/4" EXPANSION ANCHOR BOLTS PROVIDED.
 - 3.) BENCH IS SHIPPED UNASSEMBLED.

 DuMor, inc. P.O. Box 142 Mifflintown, PA 17059-0142	SCALE :	NONE	TITLE :		BENCH
	DATE DRAWN :	8/12/11	REV.	DRAWING NUMBER	
	DRAWN BY :	JSB	A	425-34/S-5	
	DATE REV. :				SHEET
	REV. BY :			1 OF 2	

STEP 1 DETAIL

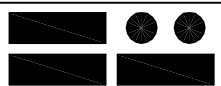
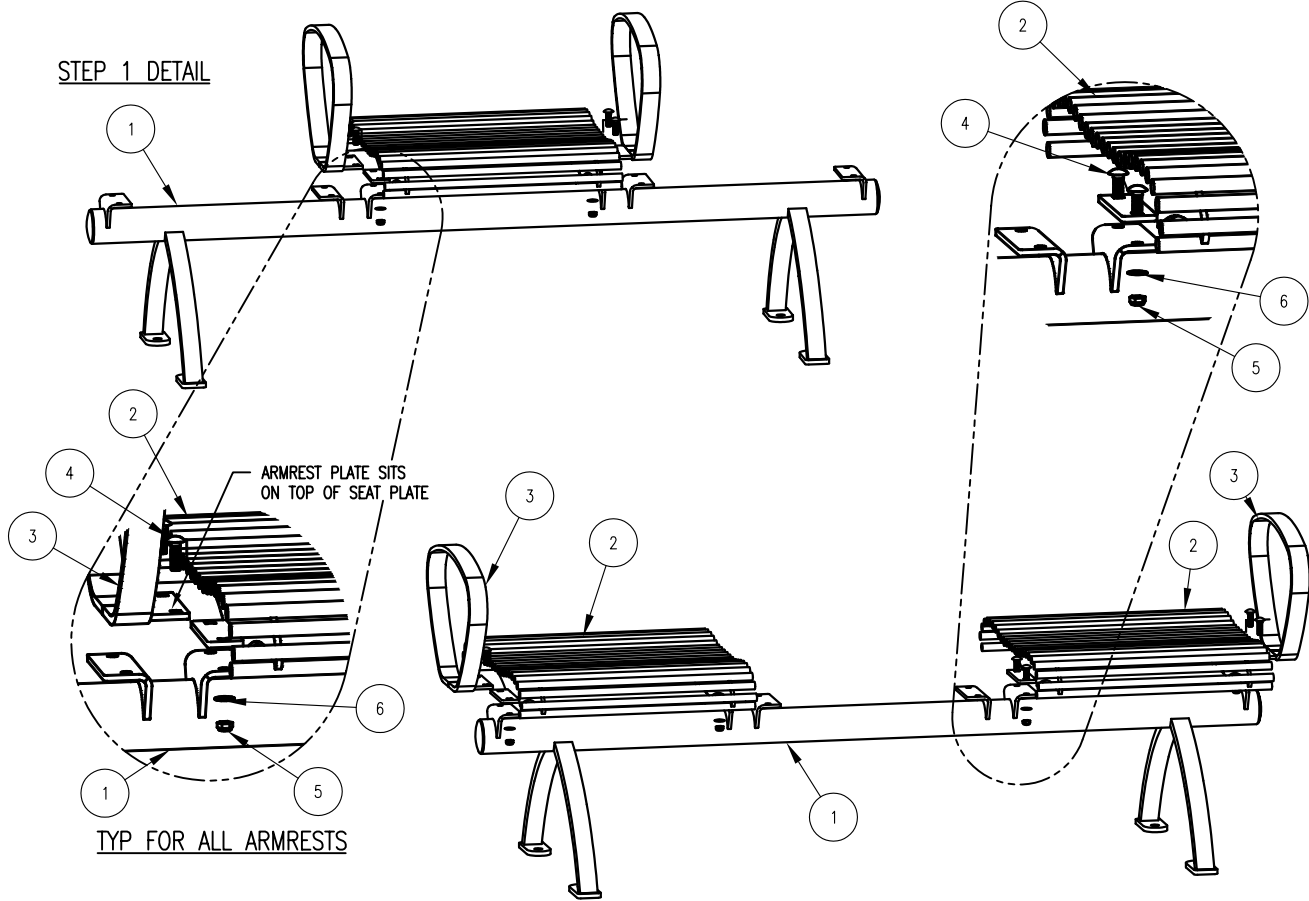

STEP 2 DETAIL

STEP 1:

- USE 1 - PC. SEAT SUPPORT FOR 3 SEATS. FREE STD (1)
- 1 - PC. STL BKLS SEAT (20") (2)
- 2 - PCS. STL ARMREST (3)
- 4 - PCS. 3/8" X 1 1/4" SS. CGE BOLT (5)
- 4 - PCS. 3/8" SS. THIN NYLON LOCKNUT (6)
- 4 - PCS. 3/8" SS. FLAT WASHER (7)

ATTACH STL BKLS SEAT (20") (2), STL ARMREST (3) TO CENTER LOCATION OF SEAT SUPPORT FOR 3 SEATS, FREE STD (4). USING HARDWARE (5, 6 & 7). TIGHTEN TO SNUG FIT.

STEP 2:

- USE 1 - PC. STL BKLS SEAT (20") (2)
- 2 - PC. STL ARMREST (3)
- 8 - PCS. 3/8" X 1 1/4" SS. CGE BOLT (5)
- 8 - PCS. 3/8" SS. THIN NYLON LOCKNUT (6)
- 8 - PCS. 3/8" SS. FLAT WASHER (7)

ATTACH STL BKLS SEAT (20") (2), STL ARMREST (3) TO STEP 1 ASSEMBLY USING HARDWARE (5, 6 & 7). TIGHTEN TO SNUG FIT.

NOTE:

- 1.) DURING ASSEMBLY PROCEDURE;
DO NOT COMPLETELY TIGHTEN HARDWARE.
- 2.) THE ACTUAL PARTS WILL NOT BE NUMBERED:
NUMBERS ONLY APPLY TO DRAWING.

STEP 4:

UPON COMPLETION OF BENCH ASSEMBLY SQUARE ALL COMPONENTS THEN TIGHTEN ALL HARDWARE.

STEP 5:

MOUNT AND ANCHOR AS SPECIFIED.

ITEM	QTY	PART NO	DESCRIPTION
1	1	0-424-30-02/S-5	STL SEAT SUPPORT FOR 3 SEATS, FREE STD
2	3	0-425-00-01	STL BKLS SEAT (20")
3	4	0-425-00-02	STL ARMREST
4	12	1-11-019	3/8" X 1 1/4" SS CGE BOLT
5	12	1-20-019	3/8" SS THIN NYLON LOCKNUT
6	12	1-22-024	3/8" SS FLAT WASHER

DuMor, inc.
P.O. Box 142 Mifflintown, PA 17059-0142

SCALE : NONE
DATE DRAWN : 8/12/11
DRAWN BY : JSB
DATE REV. :
REV. BY :

TITLE : BENCH ASSEMBLY
REV. A
DRAWING NUMBER 425-34/S-5
SHEET 2 OF 2