

LENGTH OPTIONS

- 6' BENCH
- 8' BENCH

NOTES:

- 1.) ALL STL. MEMBERS COATED W/ ZINC RICH EPOXY THEN FINISHED W/ POLYESTER POWDER COATING.
- 2.) BENCH IS SHIPPED UNASSEMBLED.
- 3.) $1 \frac{1}{2}$ " X $3 \frac{3}{4}$ " EXPANSION ANCHOR BOLTS PROVIDED

DuMor, inc.
 P.O. Box 142 Mifflintown, PA 17059-0142

SCALE :	NONE
DATE DRAWN :	8/8/11
DRAWN BY :	JSB
DATE REV. :	
REV. BY :	

TITLE :		BENCH	
REV.	DRAWING NUMBER	193 SERIES	SHEET
A			1 OF 2

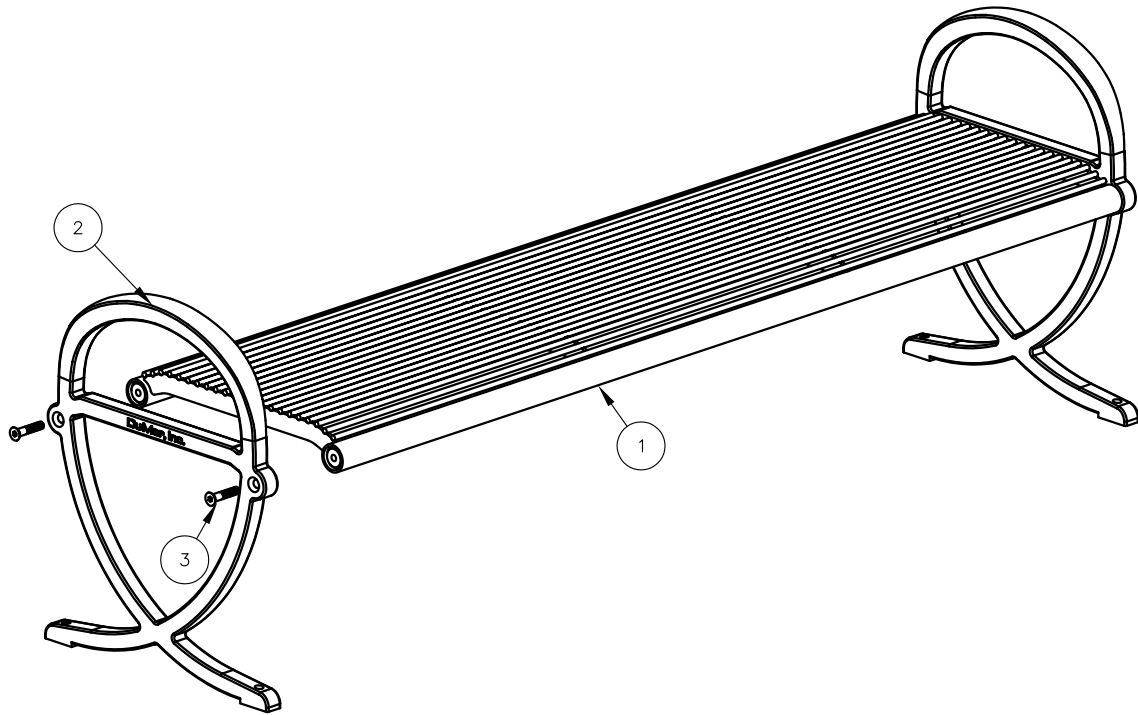

NOTE:

- 1.) DURING ASSEMBLY PROCEDURE;
DO NOT COMPLETELY TIGHTEN HARDWARE.
- 2.) THE ACTUAL PARTS WILL NOT BE NUMBERED:
NUMBERS ONLY APPLY TO DRAWING.

STEP 1:

USE 2 - PCS. BKLESS CAST IRON BENCH SUPPORT (2)
 1 - PC. 6' ALL STL SEAT (1)
 4 - PCS. 1/2" X 2 1/2" FLT. SKT. HD. CAP SCR. (3)
 ATTACH BKLESS CAST IRON SUPPORT (2) TO 6' ALL STL SEAT ASSEMBLY
 (1) USING HARDWARE (3). TIGHTEN TO SNUG FIT.

STEP 2:

UPON COMPLETION OF BENCH ASSEMBLY SQUARE ALL
 COMPONENTS THEN TIGHTEN ALL HARDWARE.

STEP 3:

MOUNT AND ANCHOR AS SPECIFIED.

ITEM	QTY	PART NO	DESCRIPTION
1	1	0-173-60-02	6' STL SEAT
2	2	0-191-00-01	BKLESS CAST IRON BENCH SUPPORT
3	4	1-12-065	1/2" X 2 1/2" FLT SKT HD CAP SCR

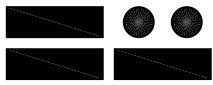
 DuMor, inc. P.O. Box 142 Mifflintown, PA 17059-0142	SCALE :	NONE	TITLE : BENCH	
	DATE DRAWN :	8/8/11		
	DRAWN BY :	JSB	REV. A	DRAWING NUMBER 193 SERIES
	DATE REV. :			
	REV. BY :			