

LENGTH OPTIONS

- 6' BENCH
- 8' BENCH

NOTES:

- 1.) ALL STL. MEMBERS COATED W/ ZINC RICH EPOXY THEN FINISHED W/ POLYESTER POWDER COATING.
- 2.) BENCH IS SHIPPED UNASSEMBLED.
- 3.) 1/2" X 3 3/4" EXPANSION ANCHOR BOLTS PROVIDED

DuMor, inc.
 P.O. Box 142 Mifflintown, PA 17059-0142

SCALE :	NONE
DATE DRAWN :	8/4/04
DRAWN BY :	AWH
DATE REV. :	1/6/09
REV. BY :	AWH

TITLE :		BENCH	
REV.	DRAWING NUMBER	164 SERIES	SHEET
B			1 OF 2

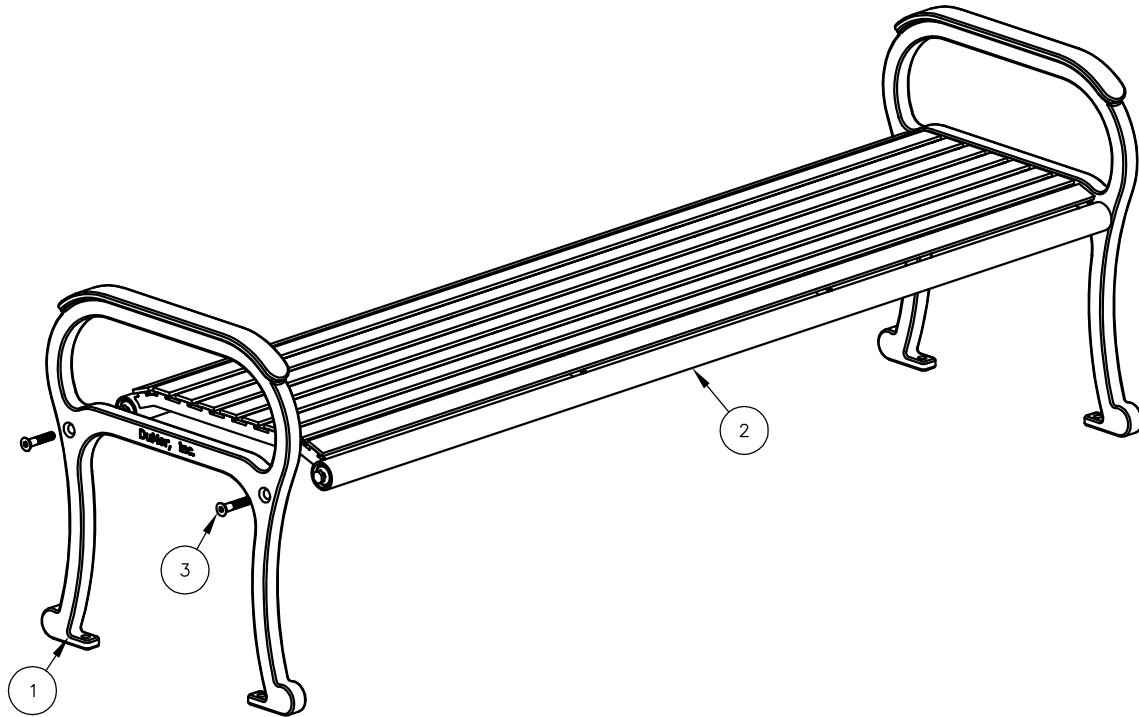

NOTE:

- 1.) DURING ASSEMBLY PROCEDURE;
DO NOT COMPLETELY TIGHTEN HARDWARE.
- 2.) THE ACTUAL PARTS WILL NOT BE NUMBERED;
NUMBERS ONLY APPLY TO DRAWING.

STEP 1:

USE 2 - PCS. BKLESS CAST IRON BENCH SUPPORT (1)
 1 - PC. 6' ALL STL SEAT (2)
 4 - PCS. 1/2" X 2 1/2" FLT. SKT. HD. CAP SCR. (3)
 ATTACH BKLESS CAST IRON SUPPORT (1) TO 6' ALL STL SEAT ASSEMBLY
 (2) USING HARDWARE (3). TIGHTEN TO SNUG FIT.

STEP 2:

UPON COMPLETION OF BENCH ASSEMBLY SQUARE ALL
 COMPONENTS THEN TIGHTEN ALL HARDWARE.

STEP 3:

MOUNT AND ANCHOR AS SPECIFIED.

ITEM	QTY	PART NO	DESCRIPTION
1	2	0-164-00-01	BKLESS CAST IRON BENCH SUPPORT
2	1	0-164-60-02	6' STL SEAT
3	4	1-12-065	1/2" X 2 1/2" FLT SKT HD CAP SCR

	SCALE :	NONE	TITLE : BENCH		
	DATE DRAWN :	8/4/04			
	DRAWN BY :	AWH	REV. B	DRAWING NUMBER 164 SERIES	SHEET 2 OF 2
	DATE REV. :	1/6/09			
	REV. BY :	AWH			