

- | | |
|---|---|
| <u>W/ 2" x 4" SLATS</u> | <u>W/ 3" x 4" SLATS</u> |
| <input type="checkbox"/> 98-82 (8' BENCH) | <input type="checkbox"/> 98-83 (8' BENCH) |

NOTES

- 1.) ALL STL. MEMBERS COATED W/ ZINC RICH EPOXY THEN FINISHED W/ POLYESTER POWDER COATING.
- 2.) ALL WOOD MEMBERS TREATED W/ CLEAR PRESERVATIVE.
- 3.) 1/2" X 3 3/4" EXPANSION ANCHOR BOLTS PROVIDED.

WOOD OPTIONS

- 'C' & BTR. DOUGLAS FIR KD S4S EE
- IPE S4S EE
- OTHER _____

DuMor, inc.
 P.O. Box 142 Mifflintown, PA 17059-0142

SCALE : NONE
 DATE DRAWN : 12/6/99
 DRAWN BY : JSB
 DATE REV. : 10/26/11
 REV. BY : ESS

TITLE : BENCH		98-80	SHEET 1 OF 2
REV. D	DRAWING NUMBER		

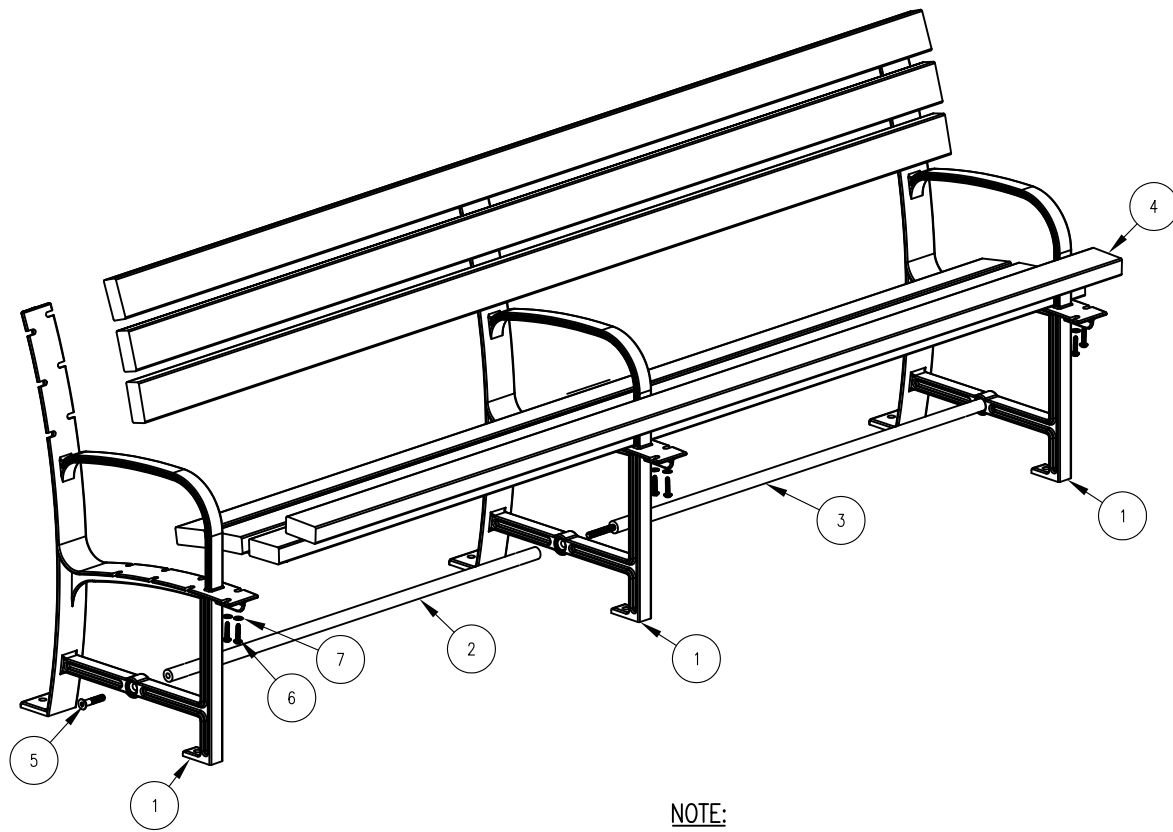

STEP 1:

USE 1 - PC. CAST IRON SUPPORT (1)
 1 - PC. 43 3/8" PIPE BRACE (2)
 1 - PC. 43 3/8" PIPE BRACE WITH STUD (3)
 ATTACH PIPE BRACES (2 & 3) TO CAST IRON SUPPORT (1) BY INSERTING PIPE BRACE WITH STUD (3) THROUGH CAST SUPPORT AND ATTACH PIPE BRACE (2) TO END OF STUD. TIGHTEN TO SNUG FIT.

STEP 2:

USE 2 - PCS. CAST IRON SUPPORT (1)
 2 - PCS. 1/2" X 2 1/2" FLT. SKT. HD. CAP SCR. (5)
 ATTACH CAST IRON SUPPORT (1) TO STEP 1 ASSEMBLY USING HARDWARE (5). TIGHTEN TO SNUG FIT.

STEP 3:

USE 7 - PCS. 2" X 4" X 95" WOOD SLAT (4)
 42 - PCS. 5/16" X 1 1/2" SS. BTN. SKT. HD. LAG (6)
 42 - PCS. 5/16" SS. FLAT WASHER (7)
 ATTACH 2" X 4" X 95" WOOD SLAT (4) TO STEP 2 ASSEMBLY USING HARDWARE (6 & 7). TIGHTEN TO SNUG FIT. REPEAT UNTIL ALL SLATS ARE ATTACHED.

NOTE:

- 1.) DURING ASSEMBLY PROCEDURE;
DO NOT COMPLETELY TIGHTEN HARDWARE.
- 2.) THE ACTUAL PARTS WILL NOT BE NUMBERED;
NUMBERS ONLY APPLY TO DRAWING.

STEP 4:

UPON COMPLETION OF BENCH ASSEMBLY SQUARE ALL COMPONENTS THEN TIGHTEN ALL HARDWARE.

STEP 5:

MOUNT AND ANCHOR AS SPECIFIED.

ITEM	QTY	PART NO	DESCRIPTION
1	3	0-98-00-02	CAST IRON SUPPORT (98)
2	1	0-98-80-03	3/4" SCH 40 PIPE BRACE (43 3/8")
3	1	0-98-80-04	3/4" SCH 40 PIPE BRACE 43 3/8" W/ STUD
4	7	0-98-82-01	2" X 4" X 95" WOOD SLAT
5	2	1-12-065	1/2" X 2 1/2" FLT SKT HD CAP SCR
6	42	1-13-023	5/16" X 1 1/2" SS BTN SKT HD LAG
7	42	1-22-017	5/16" SS FLAT WASHER

DuMor, inc.
 P.O. Box 142 Mifflintown, PA 17059-0142

SCALE : NONE
 DATE DRAWN : 12/8/99
 DRAWN BY : JSB
 DATE REV. : 12/15/08
 REV. BY : ESS

TITLE : BENCH ASSEMBLY

REV. C	DRAWING NUMBER 98-80	SHEET 2 OF 2
--------	----------------------	--------------