

S-2 SURFACE

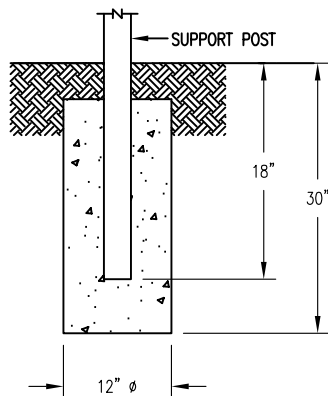

S-1 EMBEDMENT

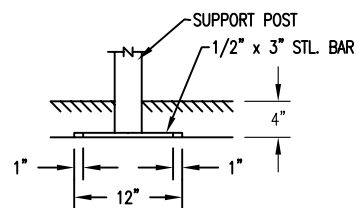
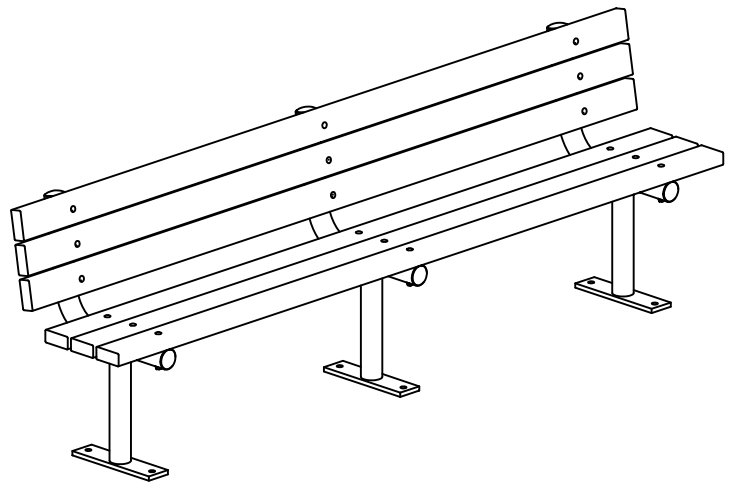

S-4 SUB FLOOR

NOTES

- 1.) ALL STL. MEMBERS COATED W/ ZINC RICH EPOXY THEN FINISHED W/ POLYESTER POWDER COATING.
- 2.) ALL WOOD MEMBERS TREATED W/ CLEAR PRESERVATIVE.
- 3.) 1/2" X 3 3/4" EXPANSION ANCHOR BOLTS PROVIDED FOR S-2 & S-4 OPTIONS.

WOOD OPTIONS

- 'C' & BTR. DOUGLAS FIR KD S4S EE
- IPE S4S EE
- OTHER _____

DuMor, inc.
 P.O. Box 142 Mifflintown, PA 17059-0142

SCALE :	NONE
DATE DRAWN :	11/11/99
DRAWN BY :	JSB
DATE REV. :	10/26/11
REV. BY :	ESS

TITLE :	BENCH		
REV. :	C	DRAWING NUMBER :	79-80
			SHEET : 1 OF 2

SURFACE MOUNT
OPTION SHOWN

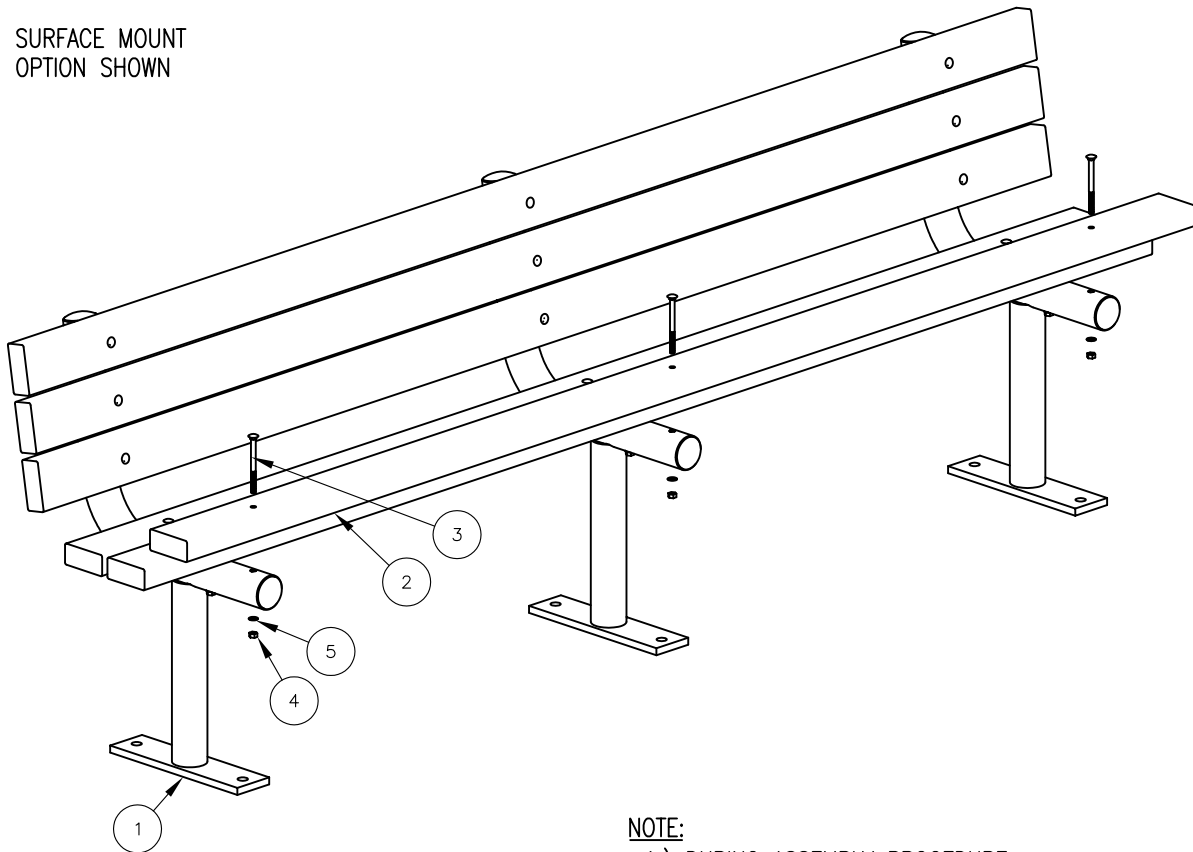

NOTE:

- 1.) DURING ASSEMBLY PROCEDURE;
DO NOT COMPLETELY TIGHTEN HARDWARE.
- 2.) THE ACTUAL PARTS WILL NOT BE NUMBERED:
NUMBERS ONLY APPLY TO DRAWING.
- 3.) SEE SPEC. SHEET 1 FOR MOUNTING OPTION.

STEP 1:

USE 3 - PCS. SUPPORT FOR SURFACE MOUNT (1)
 6 - PCS. 2" X 4" X 95" WOOD SLAT (2)
 18 - PCS. 5/16" X 4" SS. CGE. BOLT (3)
 18 - PCS. 5/16" SS. HEX NUT (4)
 18 - PCS. 3/8" I.D. X 5/8" O.D. RUBBER WASHER (5)
 ATTACH SLATS (2) TO SUPPORT FOR SURFACE MOUNT (1)
 USING HARDWARE (3, 4 & 5). TIGHTEN TO SNUG FIT.
 REPEAT UNTIL SLATS ARE ATTACHED.

STEP 2:

UPON COMPLETION OF BENCH ASSEMBLY SQUARE
 COMPONENTS THEN TIGHTEN ALL HARDWARE.

STEP 3:

ANCHOR ACCORDING TO SUPPORT OPTION USED.

ITEM	QTY	PART NO	DESCRIPTION
1	3	0-79-00-02/S-2	SUPPORT FOR SURFACE MOUNT
2	6	0-79-80-01	2" X 4" X 8" WOOD SLAT
3	18	1-11-001	5/16" X 4" SS CGE BOLT
4	18	1-21-015	5/16" SS HEX NUT
5	18	1-22-018	3/8" ID X 5/8" OD RUBBER WASHER

 DuMor, inc. P.O. Box 142 Mifflintown, PA 17059-0142	SCALE :	NONE	TITLE : BENCH ASSEMBLY		
	DATE DRAWN :	11/11/99			
	DRAWN BY :	JSB	REV. B	DRAWING NUMBER 79-80	SHEET 2 OF 2
	DATE REV. :	12/15/08			
REV. BY :	ESS				