

S-2 SURFACE

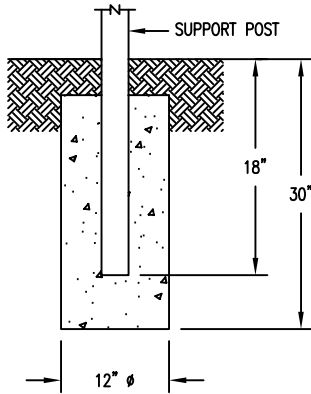

S-1 EMBEDMENT

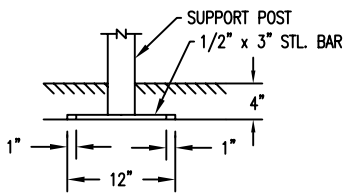

S-4 SUB FLOOR

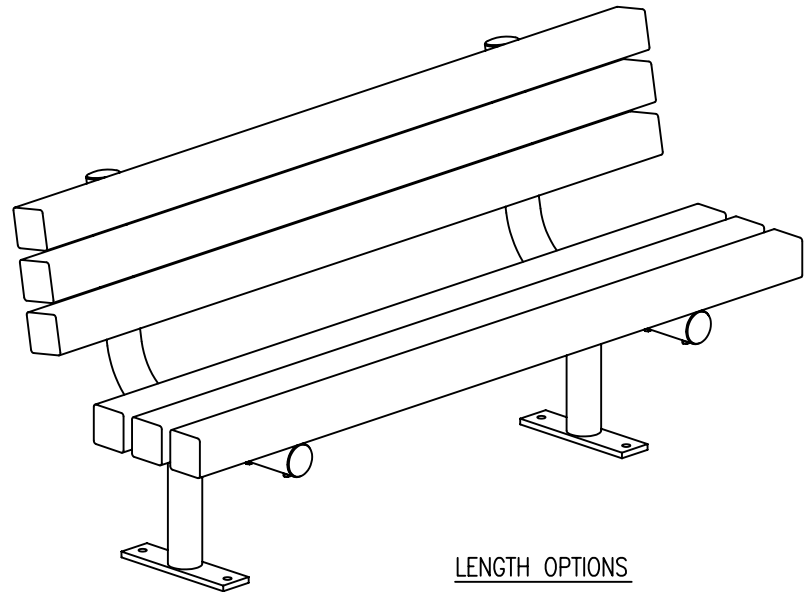
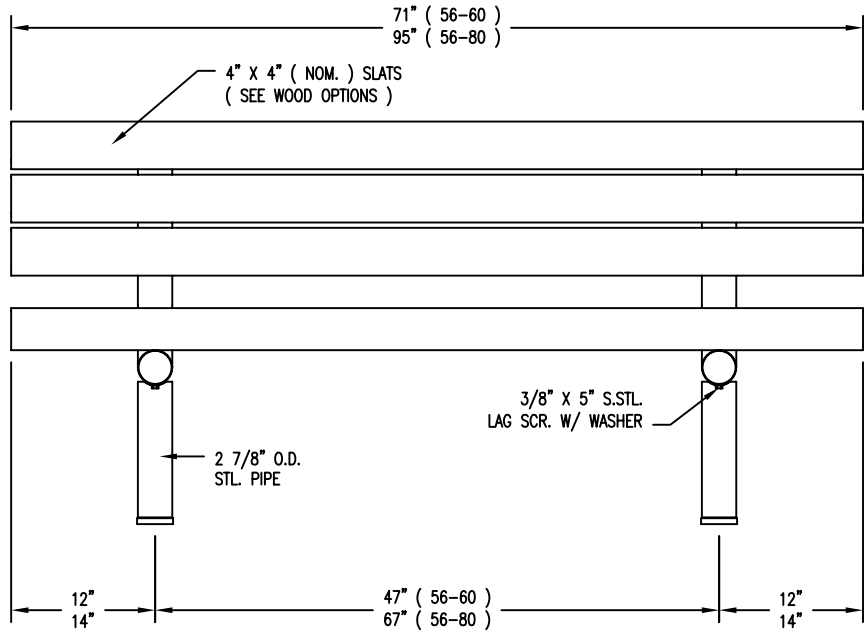

LENGTH OPTIONS

- 6' BENCH
- 8' BENCH

NOTES

- 1.) ALL STL. MEMBERS COATED W/ ZINC RICH EPOXY THEN FINISHED W/ POLYESTER POWDER COATING.
- 2.) ALL WOOD MEMBERS TREATED W/ CLEAR PRESERVATIVE.
- 3.) 1/2" X 3 3/4" EXPANSION ANCHOR BOLTS PROVIDED FOR S-2, & S-4 OPTIONS.

WOOD OPTIONS

- 'C' & BTR. DOUGLAS FIR KD S4S EE
- IPE S4S EE
- OTHER _____

DuMor, inc.
P.O. Box 142 Mifflintown, PA 17059-0142

SCALE : NONE
 DATE DRAWN : 3/22/94
 DRAWN BY : AH
 DATE REV. : 10/26/11
 REV. BY : ESS

TITLE : BENCH
 REV. G
 DRAWING NUMBER 56 SERIES

SHEET 1 OF 2

SURFACE MOUNT
OPTION SHOWN

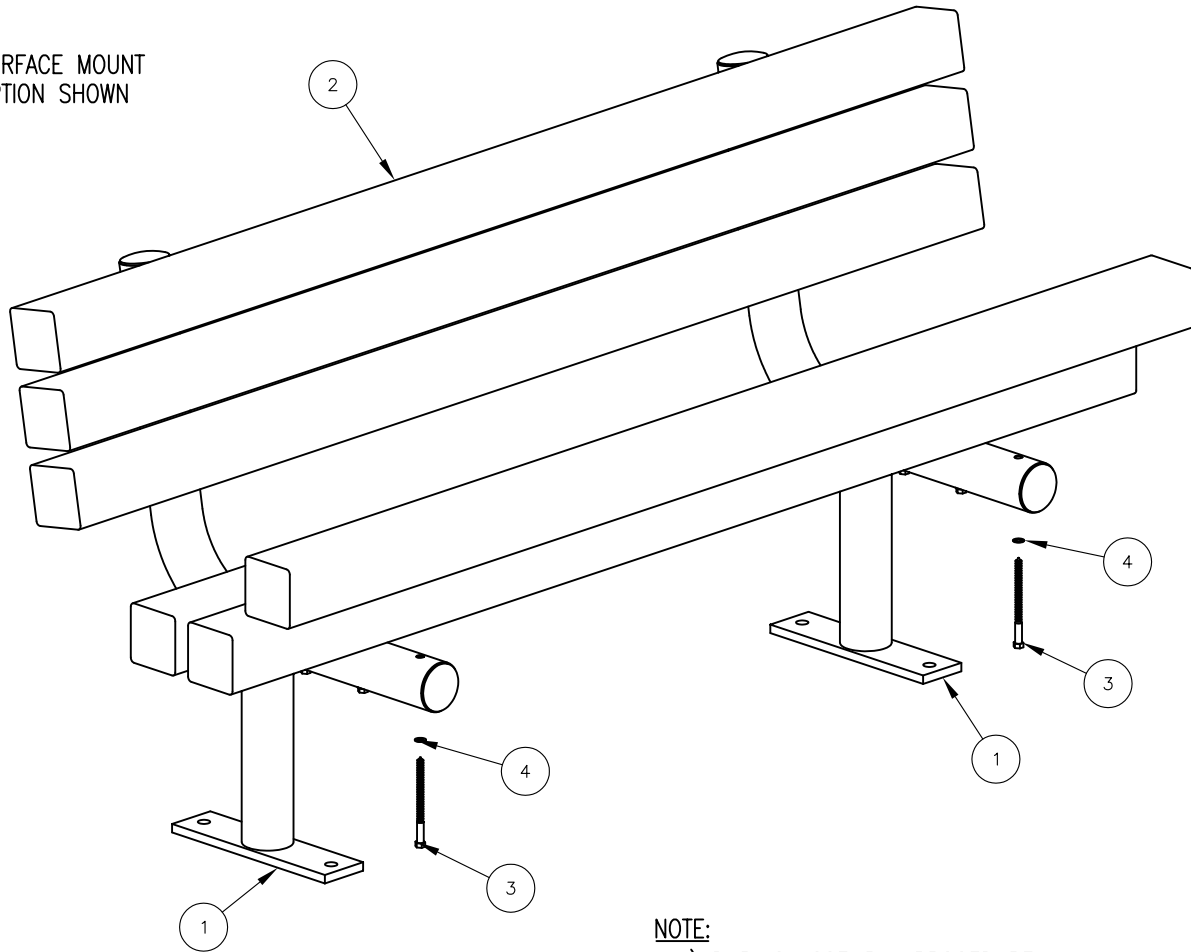

NOTE:

- 1.) DURING ASSEMBLY PROCEDURE;
DO NOT COMPLETELY TIGHTEN HARDWARE.
- 2.) THE ACTUAL PARTS WILL NOT BE NUMBERED;
NUMBERS ONLY APPLY TO DRAWING.
- 3.) SEE SPEC. SHEET 1 FOR MOUNTING OPTION.

STEP 1:

USE 2 - PCS. SUPPORT POST FOR SURFACE MOUNT (1)
 6 - PCS. 4" X 4" X 71" WOOD SLAT (2)
 12 - PCS. 3/8" X 5" SS. HEX HD. LAG SCR. (3)
 12 - PCS. 3/8" ID X 5/8" OD RUBBER WASHER (4)
 ATTACH 4" X 4" X 71" WOOD SLAT (2) TO SUPPORTS POST FOR
 SURFACE MOUNT (1) USING HARDWARE (3 & 4). TIGHTEN TO
 SNUG FIT.

STEP 2:

UPON COMPLETION OF BENCH ASSEMBLY SQUARE ALL
 COMPONENTS THEN TIGHTEN ALL HARDWARE.

STEP 3:

ANCHOR ACCORDING TO SUPPORT OPTION USED.

ITEM	QTY	PART NO	DESCRIPTION
1	2	0-56-00-02/S-2	SUPPORT POST FOR SURFACE MOUNT
2	6	0-56-60-01	4" X 4" X 71" WOOD SLAT
3	12	1-13-019	3/8" X 5" SS HEX HD LAG SCR
4	12	1-22-018	3/8" ID X 5/8" OD RUBBER WASHER
5	1	K-ANC0860-4	1/2" X 3 3/4" SS ANCHOR KIT (4PC)
6	1	K-HL0680-12RUB	3/8" LAG HARDWARE KIT (12PC)

 DuMor, inc. P.O. Box 142 Mifflintown, PA 17059-0142	SCALE :	NONE	TITLE : BENCH ASSEMBLY	
	DATE DRAWN :	3/22/94		
	DRAWN BY :	AH	REV.	DRAWING NUMBER 56 SERIES
	DATE REV. :	12/15/08	F	
REV. BY :	ESS			