

WOOD OPTIONS

- C' & BTR. DOUGLAS FIR KD S4S EE
- IPE S4S EE
- OTHER _____

NOTES

- 1.) ALL STL. MEMBERS COATED W/ ZINC RICH EPOXY THEN FINISHED W/ POLYESTER POWDER COATING.
- 2.) 1/2" X 3 3/4" EXPANSION ANCHOR BOLTS PROVIDED.

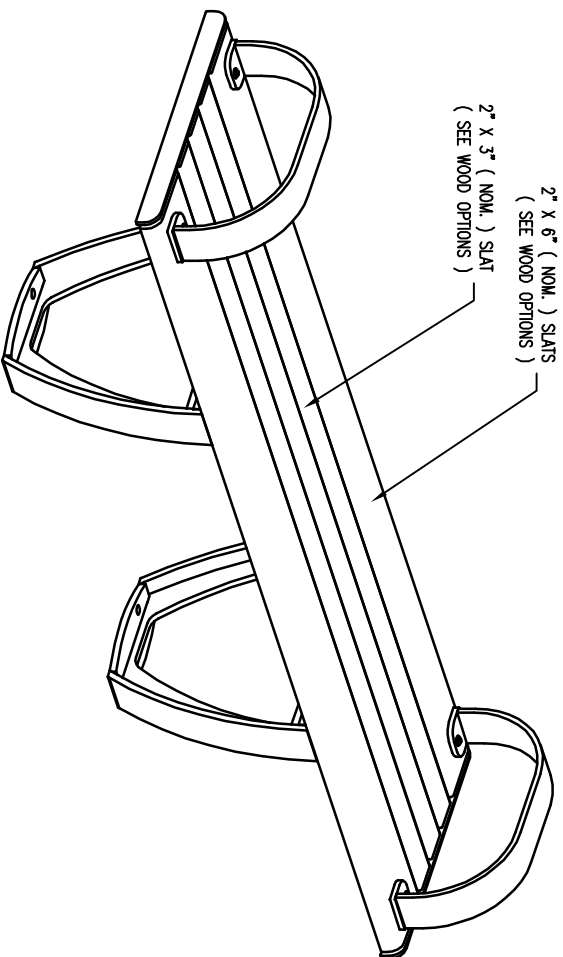

BENCH

DATE DRAWN : 03/14/16
 DRAWN BY : ESS
 DATE REV. :
 REV. BY :

REV. A

DRAWING NUMBER

471-60-2AR/S-2

SHEET 1 OF 1

- NOTES:**
- 1.) DURING ASSEMBLY PROCEDURE: DO NOT COMPLETELY TIGHTEN HARDWARE.
 - 2.) THE ACTUAL PARTS WILL NOT BE NUMBERED. NUMBERS ONLY APPLY TO DRAWING.
 - 3.) UPON COMPLETION OF ASSEMBLY SQUARE ALL COMPONENTS THEN TIGHTEN ALL HARDWARE.
 - 4.) MOUNT AND ANCHOR AS SPECIFIED.

TOOLS REQ'D

- 3/4" WRENCH
- 1/2" WRENCH
- 1/4" ALLEN WRENCH
- 1/2" MASONRY DRILL BIT
- DRILL

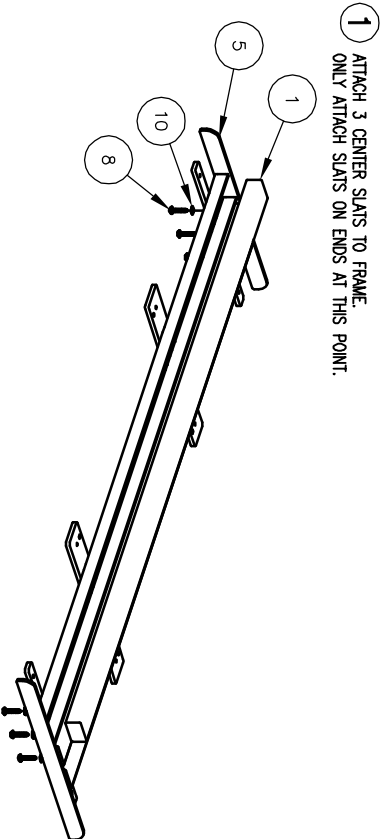

- 1** ATTACH 3 CENTER SLATS TO FRAME. ONLY ATTACH SLATS ON ENDS AT THIS POINT.

- 2** ATTACH FRAME TO SUPPORTS. INSERT HARDWARE THROUGH SUPPORT INTO TAPPED HOLES IN FRAME.

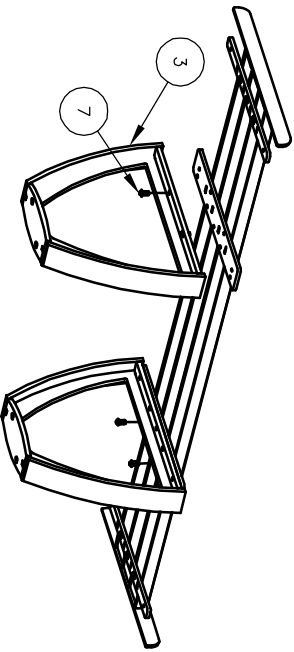

- 3** ATTACH ARMREST SLATS. INSERT SLAT HARDWARE THROUGH SUPPORT & FRAME INTO SLATS.

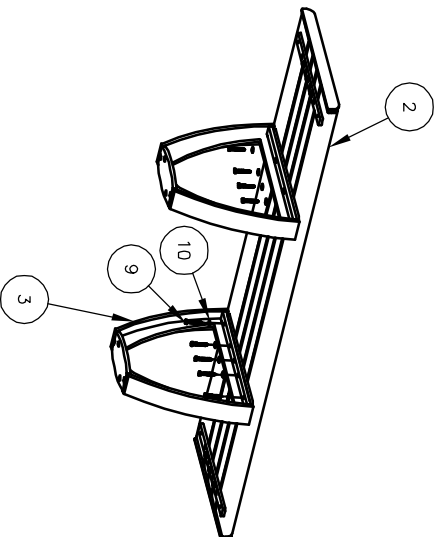

- 4** ATTACH ARMRESTS. INSERT HARDWARE THROUGH ARMRESTS & SLATS INTO TAPPED HOLES IN FRAME.

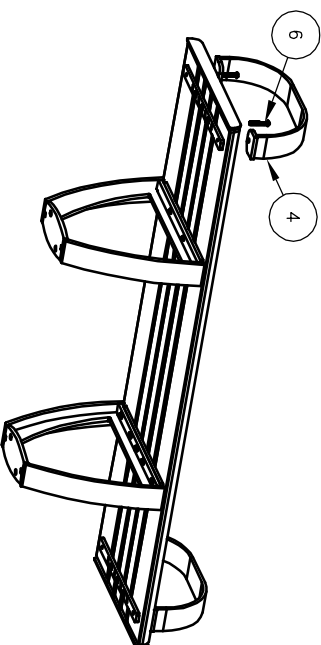

KITS PROVIDED

ITEM	QTY	PART NO	DESCRIPTION
11	1	K-ANCO860-4	1/2" X 3 3/4" SS ANCHOR KIT (4PC)
12	1	K-BO0612-4	3/8" CAP HARDWARE KIT (4PC)
13	2	K-BO0636-2	3/8" CAP HARDWARE KIT (2PC)
14	1	K-BL0524-10	5/16" LAG HARDWARE KIT (10PC)
15	1	K-HL0532-10	5/16" LAG HARDWARE KIT (10PC)

PARTS LIST

ITEM	QTY	PART NO	DESCRIPTION
1	3	0-470-60-03	71" INTR SLAT, WOOD
2	2	0-470-60-25	2" X 6" X 71" EDGE PROFILE SLAT, 2 ARMS, WOOD
3	2	0-471-00-01	STL BKLS SUPPORT
4	2	0-471-00AR-06	STL BOLT ON ARMREST
5	1	0-471-60-02	6" STL BKLS SEAT FRAME
6	4	1-12-010	3/8" X 2 1/4" SS BUTTON SKT HD CAP SCR
7	4	1-12-133	3/8" X 3/4" SS BIN SKT HD CAP SCR
8	6	1-13-023	5/16" X 1 1/2" SS BIN SKT HD LAG
9	10	1-13-038	5/16" X 2" SS HEX HD LAG SCR
10	16	1-22-017	5/16" SS FLAT WASHER



ASSEMBLY INSTRUCTIONS

DATE DRAWN : 03/14/16	REV.
DRAWN BY : ESS	A
DATE REV. : 00/00/00	
REV. BY : XXX	

DRAWING NUMBER

471-60-2AR/S-2