

NOTES:

- 1.) ALL STL. MEMBERS COATED W/ ZINC RICH EPOXY THEN FINISHED W/ POLYESTER POWDER COATING.
- 2.) 1/2" X 3 3/4" EXPANSION ANCHOR BOLTS PROVIDED.
- 3.) BENCH IS SHIPPED UNASSEMBLED.

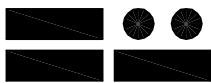

DuMor, inc.
P.O. Box 142 Mifflintown, PA 17059-0142

SCALE :	NONE
DATE DRAWN :	8/15/11
DRAWN BY :	JSB
DATE REV. :	
REV. BY :	

TITLE :	BENCH	
REV.	DRAWING NUMBER	426-23/S-5
A		

SHEET
1 OF 2

STEP 1 DETAIL

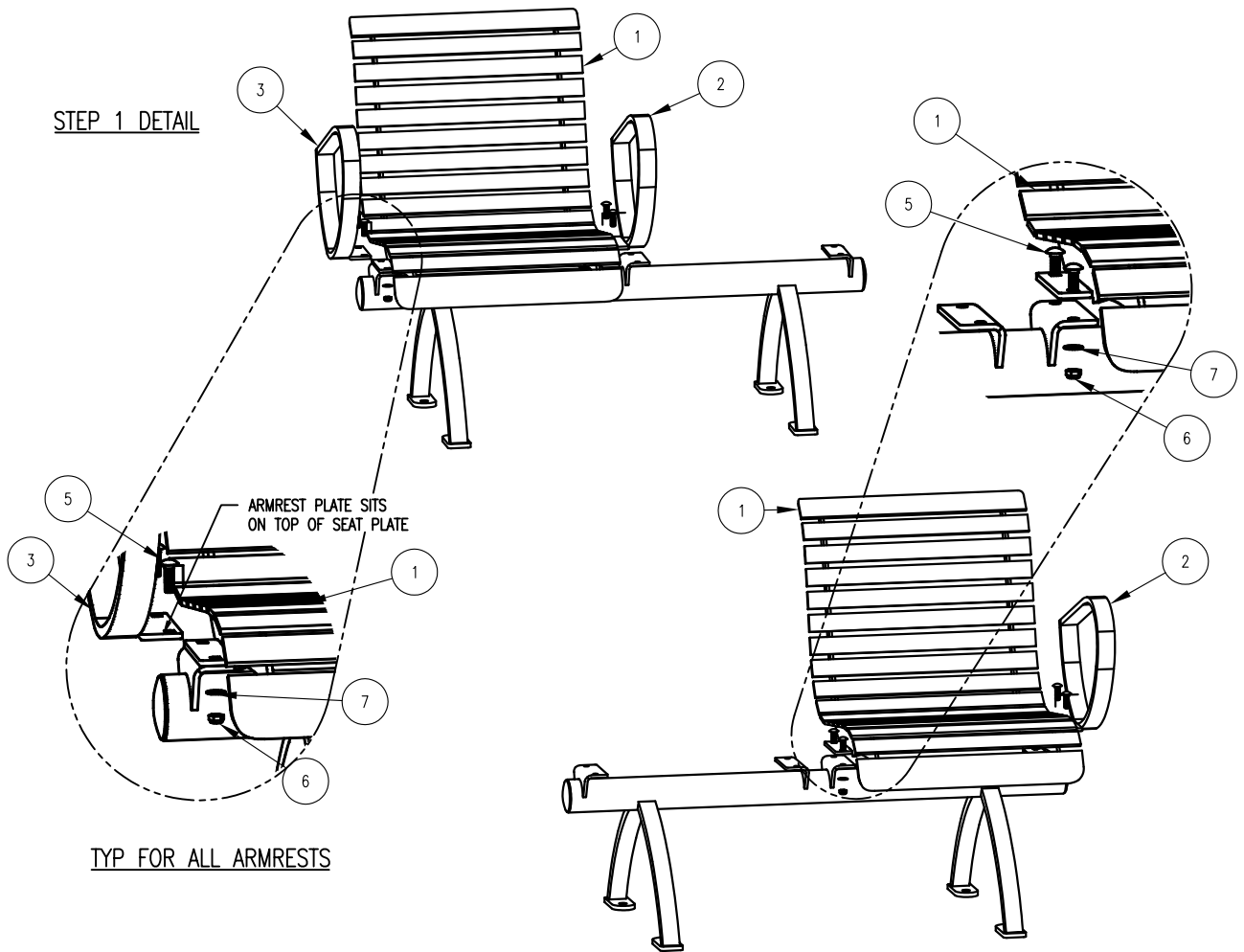

STEP 2 DETAIL

STEP 1:

- USE 1 - PC. SEAT SUPPORT FOR 2 SEATS. FREE STD (4)
 - 1 - PC. STL SEAT (20") (1)
 - 1 - PC. LEFT STL ARMREST (2)
 - 1 - PC. RIGHT STL ARMREST (3)
 - 4 - PCS. 3/8" X 1 1/4" SS. CGE BOLT (5)
 - 4 - PCS. 3/8" SS. THIN NYLON LOCKNUT (6)
 - 4 - PCS. 3/8" SS. FLAT WASHER (7)
- ATTACH STL SEAT (20") (1), LEFT STL ARMREST (2) & RIGHT STL ARMREST (3) TO END LOCATION OF SEAT SUPPORT FOR 2 SEATS, FREE STD (4). USING HARDWARE (5, 6 & 7). TIGHTEN TO SNUG FIT.

STEP 2:

- USE 1 - PC. STL SEAT (20") (1)
 - 1 - PC. LEFT STL ARMREST (2)
 - 4 - PCS. 3/8" X 1 1/4" SS. CGE BOLT (5)
 - 4 - PCS. 3/8" SS. THIN NYLON LOCKNUT (6)
 - 4 - PCS. 3/8" SS. FLAT WASHER (7)
- ATTACH STL SEAT (20") (1), LEFT STL ARMREST (2) TO STEP 1 ASSEMBLY USING HARDWARE (5, 6 & 7). TIGHTEN TO SNUG FIT.

NOTE:

- 1.) DURING ASSEMBLY PROCEDURE;
DO NOT COMPLETELY TIGHTEN HARDWARE.
- 2.) THE ACTUAL PARTS WILL NOT BE NUMBERED:
NUMBERS ONLY APPLY TO DRAWING.

STEP 4:

UPON COMPLETION OF BENCH ASSEMBLY SQUARE ALL COMPONENTS THEN TIGHTEN ALL HARDWARE.

STEP 5:

MOUNT AND ANCHOR AS SPECIFIED.

ITEM	QTY	PART NO	DESCRIPTION
1	2	0-426-00-01	STL SEAT (20")
2	2	0-424-00L-03	LEFT STL ARMREST
3	1	0-424-00R-03	RIGHT STL ARMREST
4	1	0-424-20-02/S-5	STL SEAT SUPPORT FOR 2 SEATS, FREE STD
5	8	1-11-019	3/8" X 1 1/4" SS CGE BOLT
6	8	1-20-019	3/8" SS THIN NYLON LOCKNUT
7	8	1-22-024	3/8" SS FLAT WASHER

DuMor, inc.
P.O. Box 142 Mifflintown, PA 17059-0142

SCALE : NONE
DATE DRAWN : 8/15/11
DRAWN BY : JSB
DATE REV. :
REV. BY :

TITLE : BENCH ASSEMBLY
REV. A
DRAWING NUMBER 426-23/S-5
SHEET 2 OF 2