

NOTES

- 1.) ALL STL. MEMBERS COATED W/ ZINC RICH EPOXY THEN FINISHED W/ POLYESTER POWDER COATING.
- 2.) $1/2" \times 3 \frac{3}{4}"$ EXPANSION ANCHOR BOLTS PROVIDED.

DuMor, inc.
 P.O. Box 142 Mifflintown, PA 17059-0142

SCALE : NONE
 DATE DRAWN : 11/9/10
 DRAWN BY : JSB
 DATE REV. :
 REV. BY :

TITLE : BENCH
 REV. A
 DRAWING NUMBER 194-60

SHEET
 1 OF 2

NOTE:

- 1.) DURING ASSEMBLY PROCEDURE;
DO NOT COMPLETELY TIGHTEN HARDWARE.
- 2.) THE ACTUAL PARTS WILL NOT BE NUMBERED;
NUMBERS ONLY APPLY TO DRAWING.

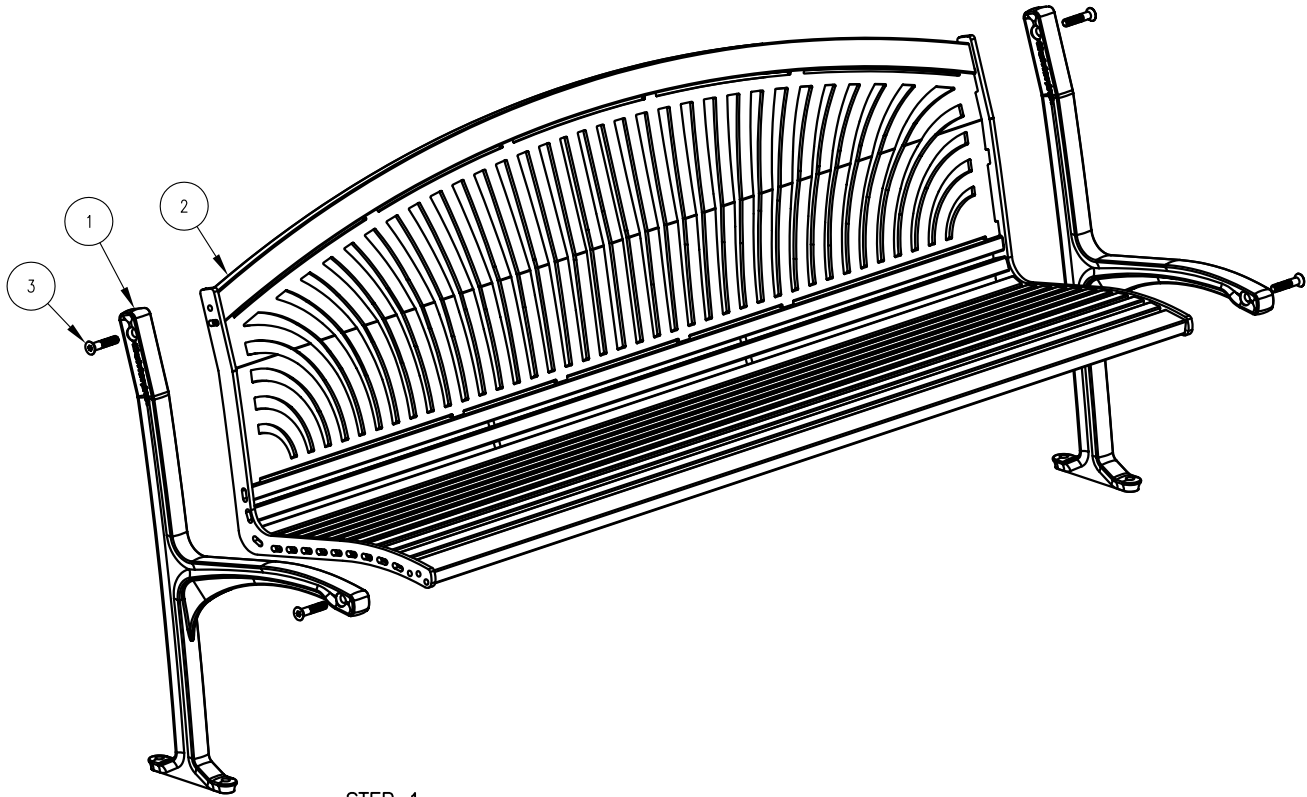

STEP 1:

USE 2 - PCS. DUCTILE IRON END SUPPORT (1)
 1 - PC. 6' STL SEAT (2)
 4 - PCS. 1/2" X 2 1/2" FLT. SKT. HD. CAP SCR. (3)
 ATTACH DUCTILE IRON END SUPPORT (1) TO 6' STL SEAT
 (2) USING HARDWARE (3). TIGHTEN TO SNUG FIT.

STEP 2:

UPON COMPLETION OF BENCH ASSEMBLY SQUARE
 ALL COMPONENTS THEN TIGHTEN ALL HARDWARE.

STEP 3:

MOUNT AND ANCHOR AS SPECIFIED.

ITEM	QTY	PART NO	DESCRIPTION
1	2	0-185-00-01	DUCTILE IRON END SUPPORT
2	1	0-194-60-01	6' STL SEAT
3	4	1-12-065	1/2" X 2 1/2" FLT SKT HD CAP SCR

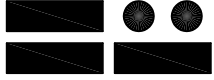
 DuMor, inc. P.O. Box 142 Mifflintown, PA 17059-0142	SCALE :	NONE	TITLE : BENCH ASSEMBLY	
	DATE DRAWN :	11/9/10		
	DRAWN BY :	JSB	REV.	DRAWING NUMBER 194-60
	DATE REV. :		A	
	REV. BY :			