

LENGTH OPTIONS

- 6' BENCH
- 8' BENCH

NOTES

- 1.) ALL STL. MEMBERS COATED W/ ZINC RICH COATING THEN POLYESTER POWDER COATED.
- 2.) BENCH IS SHIPPED UNASSEMBLED.
- 3.) 1/2" X 3 3/4" EXPANSION ANCHOR BOLTS PROVIDED.



DuMor, inc.
P.O. Box 142 Mifflintown, PA 17059-0142

SCALE : NONE
DATE DRAWN : 09/23/10
DRAWN BY : ESS
DATE REV. :
REV. BY :

TITLE : BENCH

REV. A	DRAWING NUMBER 190 SERIES
--------	---------------------------

SHEET 1 OF 2

NOTE:

- 1.) DURING ASSEMBLY PROCEDURE;
DO NOT COMPLETELY TIGHTEN HARDWARE.
- 2.) THE ACTUAL PARTS WILL NOT BE NUMBERED;
NUMBERS ONLY APPLY TO DRAWING.

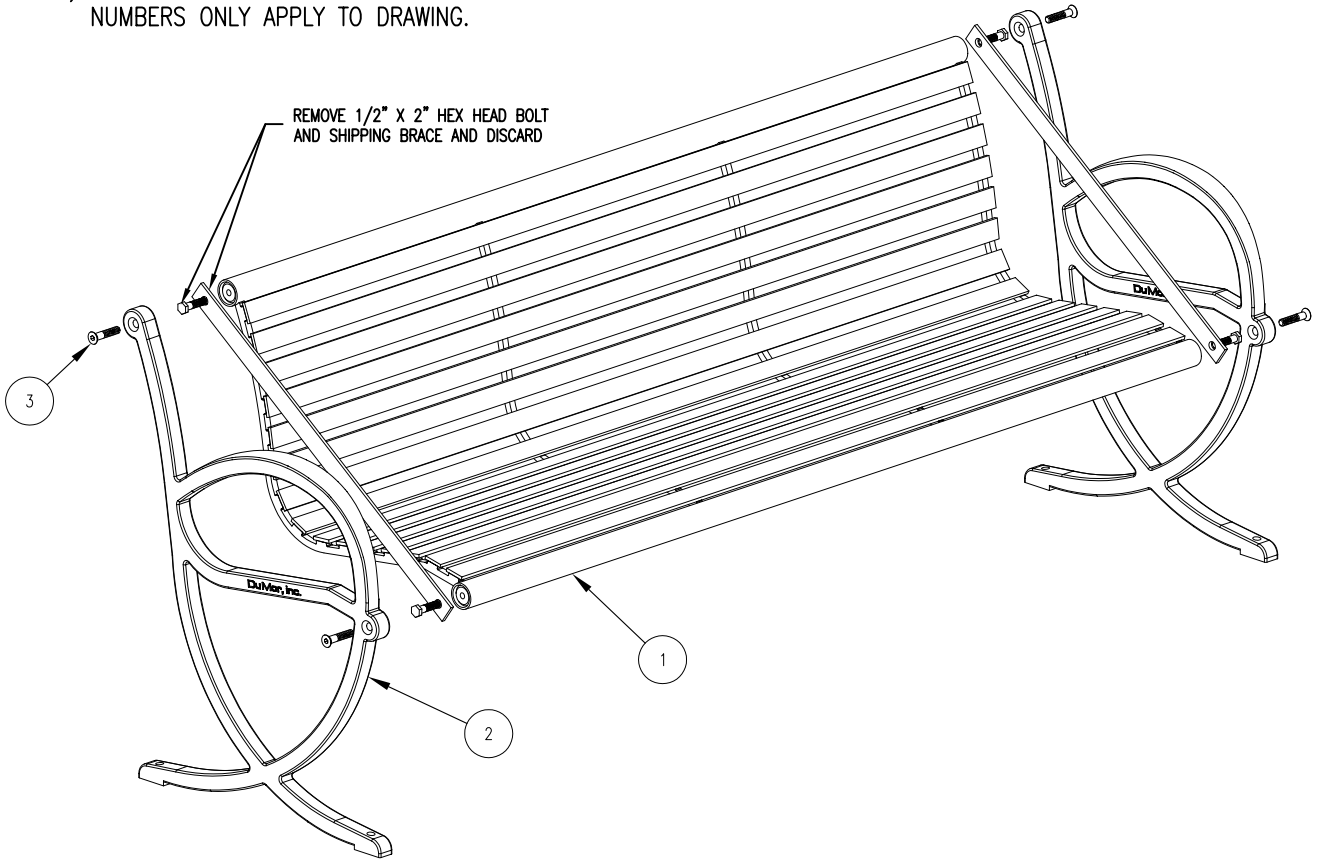

STEP 1:

USE 2 - PCS. CAST IRON BENCH SUPPORT W/ BACK (2)
 1 - PC. 6' ALL STL WELDED SEAT SECTION (1)
 4 - PCS. 1/2" X 2 1/2" FLT. SKT. HD. CAP SCR. (3)
 ATTACH CAST IRON BENCH SUPPORT W/ BACK (2) TO 6' ALL
 STL WELDED SEAT ASSEMBLY (1) USING HARDWARE (3).
 TIGHTEN TO SNUG FIT.

STEP 2:

UPON COMPLETION OF BENCH ASSEMBLY SQUARE ALL
 COMPONENTS THEN TIGHTEN ALL HARDWARE.

STEP 3:

MOUNT AND ANCHOR AS SPECIFIED.

ITEM	QTY	PART NO	DESCRIPTION
1	1	0-160-60-02	6' STL SEAT
2	2	0-190-00-01	CAST IRON BENCH SUPPORT
3	4	1-12-065	1/2" X 2 1/2" FLT SKT HD CAP SCR

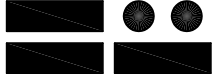
 DuMor, inc. P.O. Box 142 Mifflintown, PA 17059-0142	SCALE :	NONE	TITLE :		BENCH ASSEMBLY	
	DATE DRAWN :	09/23/10	REV.	DRAWING NUMBER	190 SERIES	SHEET 2 OF 2
	DRAWN BY :	ESS				
	DATE REV. :					
	REV. BY :					
		A				