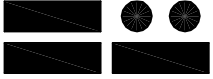

CUSTOM LETTERING (37 SPACES) _____

NOTES

- 1.) ALL STL. MEMBERS COATED W/ ZINC RICH EPOXY THEN FINISHED W/ POLYESTER POWDER COATING.
- 2.) 1/2" X 3 3/4" EXPANSION ANCHOR BOLTS PROVIDED.
- 3.) CUSTOM LETTERING AVAILABLE FOR RECESSED SIDE PANELS (TOTAL OF 37 SPACES)

 DuMor, inc. P.O. Box 142 Mifflintown, PA 17059-0142	SCALE :	NONE	TITLE :	BENCH	
	DATE DRAWN :	9/5/03		U.S. PATENT D467-101	
	DRAWN BY :	CDC	REV.	DRAWING NUMBER	162-80
	DATE REV. :	6/14/04	B		
	REV. BY :	CDC			SHEET 1 OF 2

NOTE:

- 1.) DURING ASSEMBLY PROCEDURE;
DO NOT COMPLETELY TIGHTEN HARDWARE.
- 2.) THE ACTUAL PARTS WILL NOT BE NUMBERED;
NUMBERS ONLY APPLY TO DRAWING.

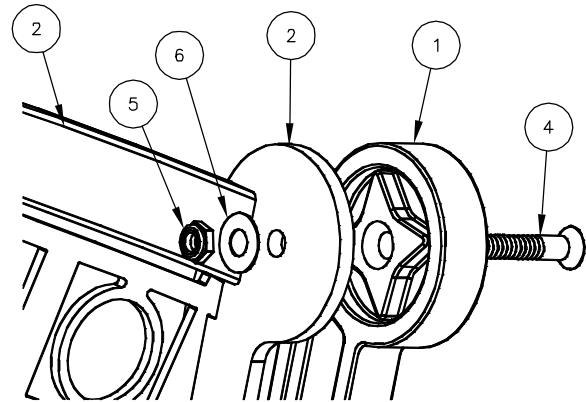
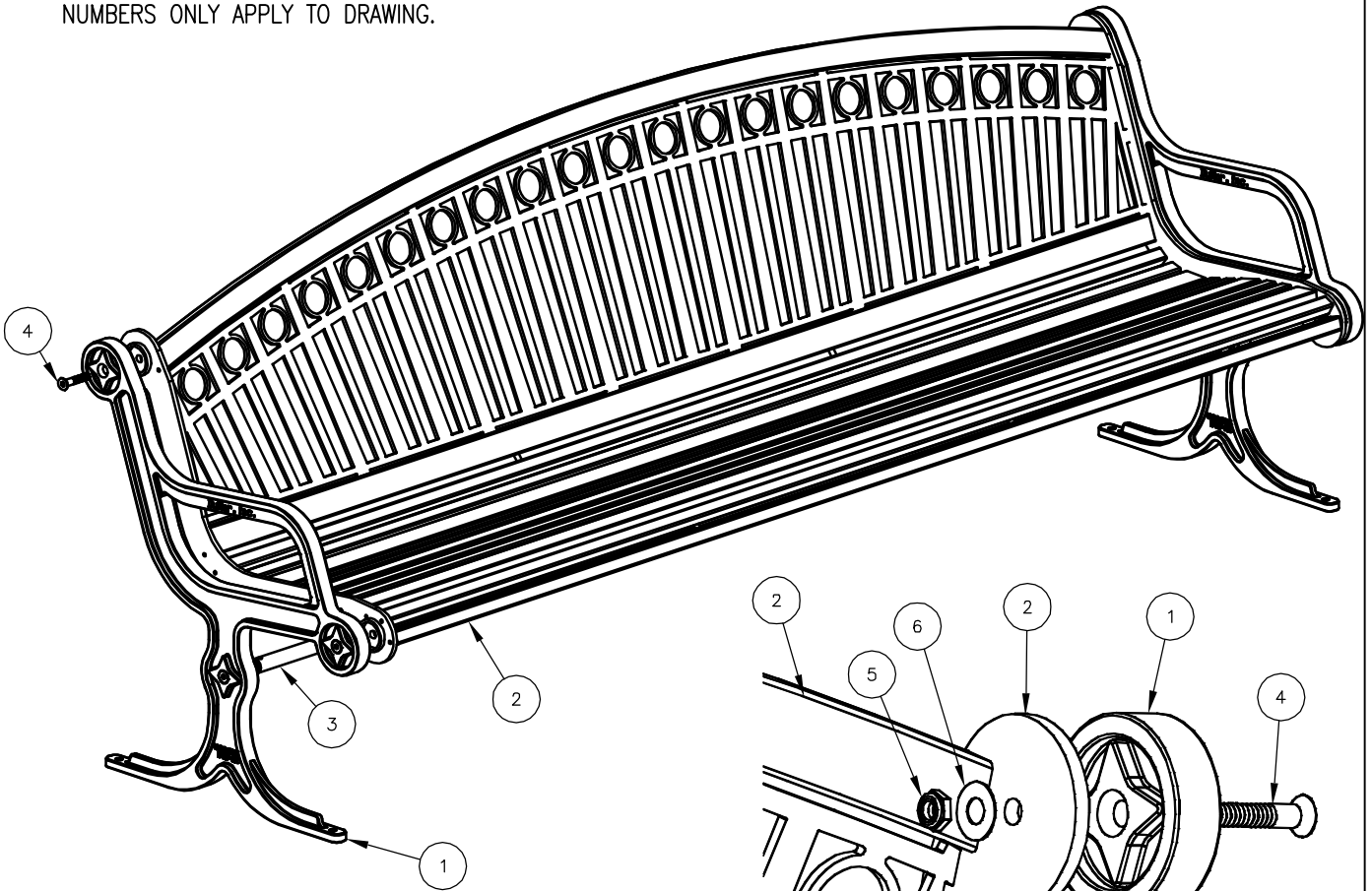

BOLTING DETAIL

STEP 1:

- USE 2 - PCS. CAST IRON END SUPPORT (1)
 - 1 - PC. 95 3/4" PIPE BRACE (3)
 - 2 - PCS. 1/2" X 2 1/2" SS. FLT. SKT. HD. CAP SCR. (4)
- ATTACH CAST IRON END SUPPORT (1) TO 95 3/4" PIPE BRACE (3) USING HARDWARE (4). TIGHTEN TO SNUG FIT.

STEP 2:

- USE 1 - PC. 8' ALL STL. SEAT ASSEMBLY (2)
 - 4 - PCS. 1/2" X 2 1/2" SS. FLT. SKT. HD. CAP SCR. (4)
 - 4 - PCS. 1/2" SS. THIN NYLON LOCK NUT (5)
 - 4 - PCS. 1/2" SS. FLAT WASHER (6)
- ATTACH SEAT ASSEMBLY (2) TO STEP 1 ASSEMBLY USING HARDWARE (4, 5, & 6) TIGHTEN TO SNUG FIT.

STEP 3:

UPON COMPLETION OF BENCH ASSEMBLY SQUARE ALL COMPONENTS THEN TIGHTEN ALL HARDWARE.

STEP 4:

MOUNT AND ANCHOR AS SPECIFIED.

ITEM	QTY	PART NO	DESCRIPTION
1	2	0-140-00-01	CAST IRON BENCH SUPPORT
2	1	0-162-80-01	8' ALL STEEL SEAT ASSEMBLY
3	1	0-57-80-04	95 3/4" PIPE BRACE
4	6	1-12-065	1/2" X 2 1/2" FLT SKT HD CAP SCR
5	4	1-20-018	1/2" SS THIN NYLON LOCKNUT
6	4	1-22-015	1/2" SS FLAT WASHER

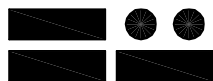

DuMor, inc.

P.O. Box 142 Mifflintown, PA 17059-0142

SCALE : NONE

DATE DRAWN : 9/5/03

DRAWN BY : CDC

DATE REV. : 6/14/04

REV. BY : CDC

TITLE : BENCH ASSEMBLY
U.S. PATENT D467-101

REV.
B

DRAWING
NUMBER

162-80

SHEET
2 OF 2