

NOTES

- 1.) ALL STL. MEMBERS COATED W/ ZINC RICH EPOXY THEN FINISHED W/ POLYESTER POWDER COATING.
- 2.) 1/2" X 3 3/4" EXPANSION ANCHOR BOLTS PROVIDED.



TABLE

DATE DRAWN : 08/26/13  
 DRAWN BY : ESS  
 DATE REV. : 10/8/15  
 REV. BY : JSB

REV.  
B

DRAWING  
NUMBER

464-60HS

SHEET  
1 OF 2

PARTS LIST

ITEM	QTY	PART NO	DESCRIPTION
1	6	0-460-60-03	71 3/4" ALUM EXTRUSION
2	2	0-460-60HS-01	6' SEAT/ BACK FOR 1/4" X 1 1/2" BAR
3	2	0-464-00-01	TABLE SUPPORT
4	1	0-464-60HS-03	6' STL TABLE TOP, 1/4" X 1 1/2" BAR
5	12	1-12-053	5/16" X 1 1/2" SS BTN SKT HD CAP SCR

KITS PROVIDED

ITEM	QTY	PART NO	DESCRIPTION
6	1	K-ANC0860-4	1/2" X 3 3/4" SS ANCHOR KIT (4PC)
7	2	K-BC0524-6	5/16" CAP HARDWARE KIT (6PC)

NOTE:

- 1.) DURING ASSEMBLY PROCEDURE; DO NOT COMPLETELY TIGHTEN HARDWARE.
- 2.) THE ACTUAL PARTS WILL NOT BE NUMBERED. NUMBERS ONLY APPLY TO DRAWING.
- 3.) UPON COMPLETION OF ASSEMBLY SQUARE ALL COMPONENTS THEN TIGHTEN ALL HARDWARE.
- 4.) MOUNT AND ANCHOR AS SPECIFIED.

TOOLS REQ'D

- 3/4" WRENCH  
 3/16" ALLEN WRENCH  
 1/2" MASONRY DRILL BIT  
 DRILL

- 1 ATTACH 3 ALUM. EXTRUSIONS AS SHOWN, TO LEFT & RIGHT TABLE SUPPORTS, ENSURE PINS ARE IN "L" SLOTS.

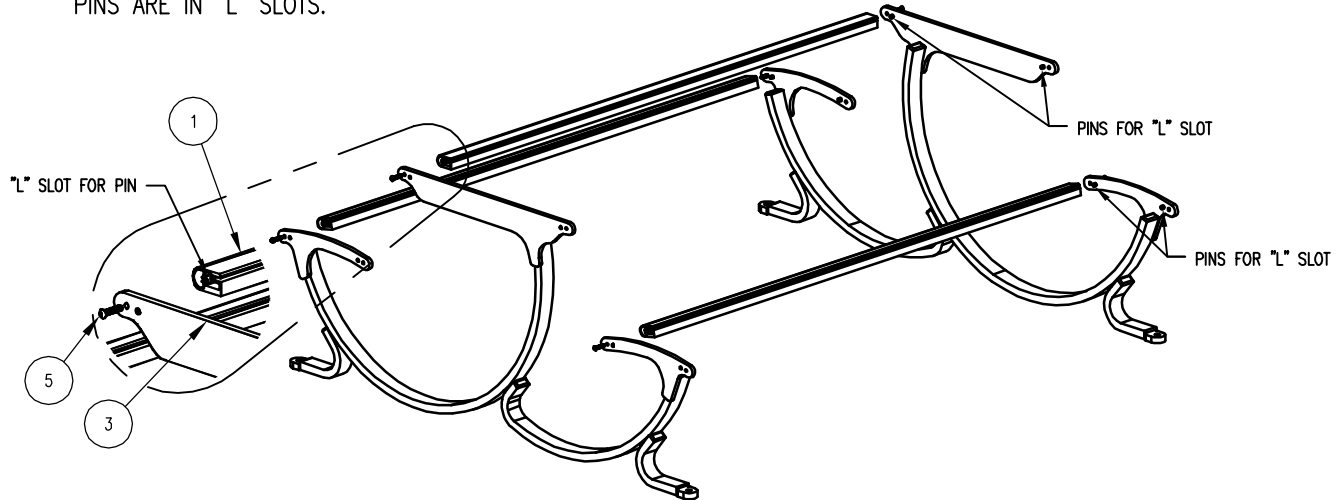

- 2 INSERT SEAT/BACK INTO STEP 1, USING SLOTS ON ALUM. EXTRUSION. \*\*NOTE: RIGHT TABLE SUPPORT NOT SHOWN FOR CLARITY.\*\*

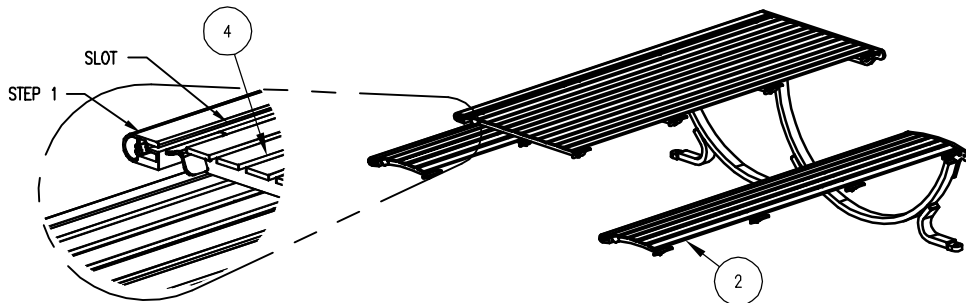

- 3 ATTACH 3 REMAINING ALUM. EXTRUSIONS TO SUPPORTS, AS IN STEP 1.

