

NOTES

- 1.) ALL STL. MEMBERS COATED W/ ZINC RICH EPOXY THEN FINISHED W/ POLYESTER POWDER COATING.
- 2.) 1/2" X 3 3/4" EXPANSION ANCHOR BOLTS PROVIDED.

PARTS LIST

ITEM	QTY	PART NO	DESCRIPTION
1	1	0-460-00L-01	LEFT BENCH SUPPORT
2	1	0-460-00R-01	RIGHT BENCH SUPPORT
3	4	0-460-60-03	71 3/4" ALUM EXTRUSION
4	2	0-460-60RB-01	6' SEAT/ BACK FOR 3/8" DIA BAR
5	8	1-12-053	5/16" X 1 1/2" SS BTN SKT HD CAP SCR

KITS PROVIDED

ITEM	QTY	PART NO	DESCRIPTION
6	1	K-ANCO860-4	1/2" X 3 3/4" SS ANCHOR KIT (4PC)
7	1	K-BC0524-8	5/16" CAP HARDWARE KIT (8PC)

NOTE:

- 1.) DURING ASSEMBLY PROCEDURE; DO NOT COMPLETELY TIGHTEN HARDWARE.
- 2.) THE ACTUAL PARTS WILL NOT BE NUMBERED. NUMBERS ONLY APPLY TO DRAWING.
- 3.) UPON COMPLETION OF ASSEMBLY SQUARE ALL COMPONENTS THEN TIGHTEN ALL HARDWARE.
- 4.) MOUNT AND ANCHOR AS SPECIFIED.

TOOLS REQ'D

- 3/4" WRENCH
- 3/16" ALLEN WRENCH
- 1/2" MASONRY DRILL BIT
- DRILL

- ① ATTACH 2 ALUM. EXTRUSIONS AS SHOWN, TO LEFT & RIGHT BENCH SUPPORTS, ENSURE PINS ARE IN "L" SLOTS.

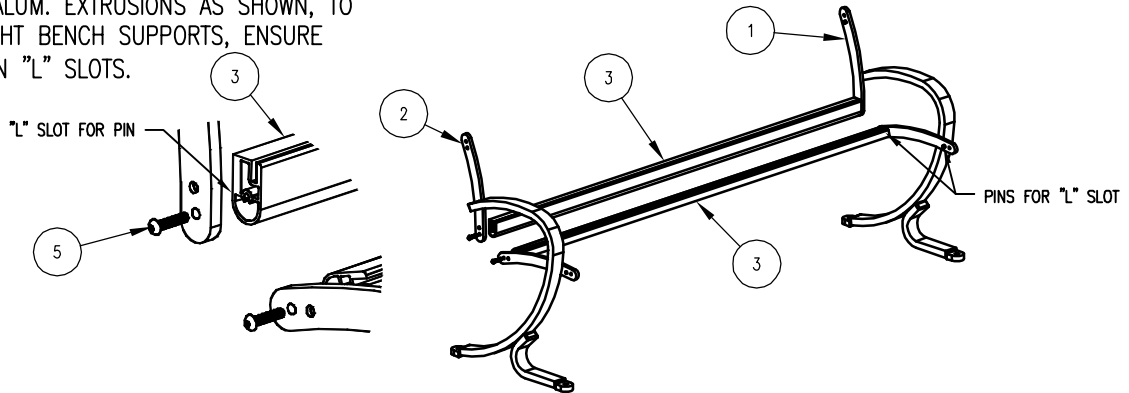

- ② INSERT SEAT/BACK INTO STEP 1, USING SLOTS ON ALUM. EXTRUSION. **NOTE: RIGHT BENCH SUPPORT NOT SHOWN FOR CLARITY.**

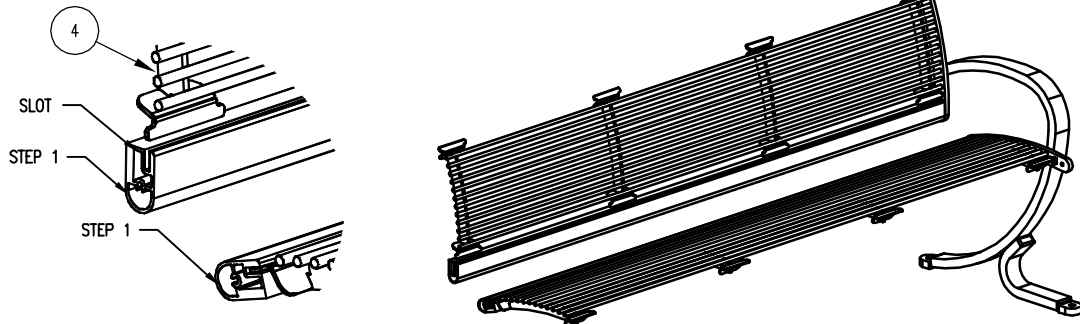

- ③ ATTACH 2 REMAINING ALUM. EXTRUSIONS TO SUPPORTS, AS IN STEP 1.

