

2" X 3" (NOM.) SLATS
(SEE WOOD OPTIONS)

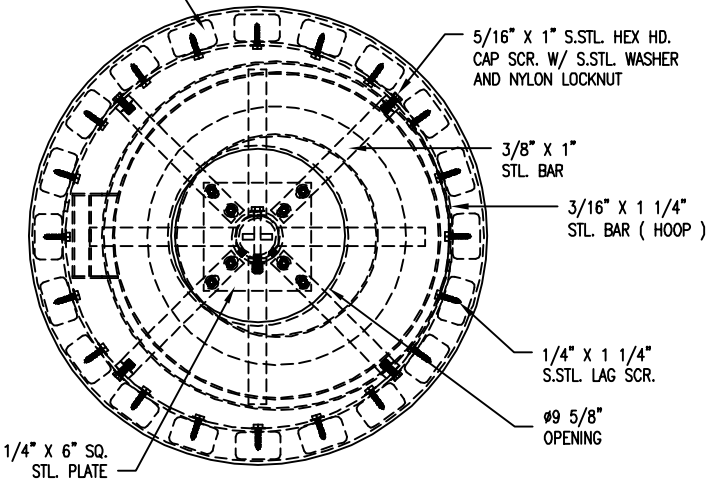

POLYETHYLENE COVER

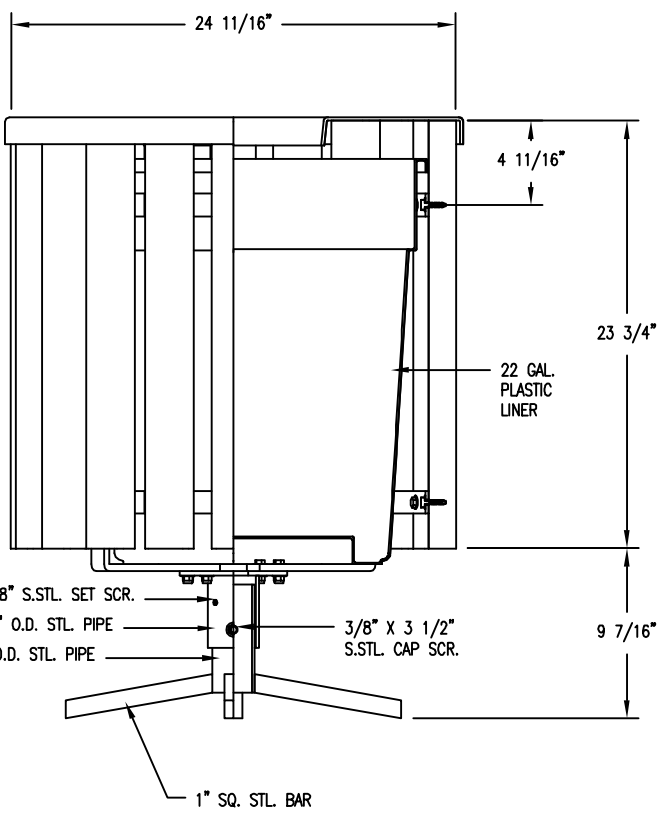
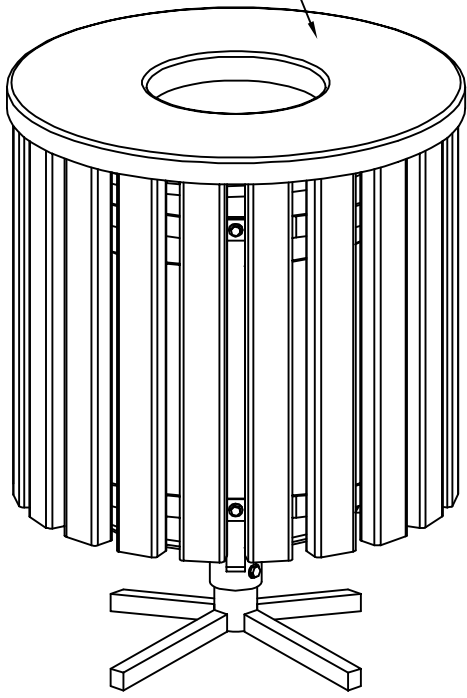

NOTES

1.) ALL STL. MEMBERS COATED W/ ZINC RICH EPOXY THEN FINISHED W/ BLACK POLYESTER POWDER COATING.

WOOD OPTIONS

- 'C' & BTR. DOUGLAS FIR KD S4S EE
- IPE S4S EE
- OTHER _____



RECEPTACLE

DATE DRAWN : 3/22/94
 DRAWN BY : AH
 DATE REV. : 10/25/11
 REV. BY : ESS

REV.
J

DRAWING NUMBER
43-22
W/ COVER 46-00

SHEET
1 OF 2

NOTES:

- 1.) DURING ASSEMBLY PROCEDURE;
DO NOT COMPLETELY TIGHTEN HARDWARE.
- 2.) THE ACTUAL PARTS WILL NOT BE NUMBERED.
NUMBERS ONLY APPLY TO DRAWING.
- 3.) UPON COMPLETION OF ASSEMBLY SQUARE
ALL COMPONENTS THEN TIGHTEN ALL HARDWARE.
- 4.) MOUNT AND ANCHOR AS SPECIFIED.

TOOLS REQ'D

- 9/16" WRENCH
- 1/2" WRENCH
- 7/16" WRENCH
- 1/4" ALLEN WRENCH
- PLIERS (FOR ATTACHING COVER)

PARTS LIST

ITEM	QTY	PART NO	DESCRIPTION
1	1	0-41-00-04	CENTER BRACKET
2	20	0-41-20-01	2" X 3" X 23 3/4" SLAT, WOOD
3	2	0-41-20-02	HOOP FOR 20 GAL (21 11/16" DIA)
4	4	0-41-20-05	"L" SUPPORT STRAP FOR 20 GAL
5	1	0-43-00-01	FREE STANDING BASE
6	1	1-12-034	3/8" X 3 1/2" SS HEX HD CAP SCR
7	2	1-12-054	3/8" X 3/8" SS SKT SET SCR
8	16	1-12-061	5/16" X 1" SS HEX HD CAP SCR
9	40	1-13-004	1/4" X 1 1/4" SS HEX HD LAG SCR
10	1	1-20-007	3/8" SS NYLON LOCKNUT
11	16	1-20-016	5/16" SS NYLON LOCKNUT
12	40	1-22-006	1/4" SS FLAT WASHER
13	32	1-22-017	5/16" SS FLAT WASHER
14	2	1-22-024	3/8" SS FLAT WASHER
15	1	49-22	22 GAL PL LINER W/HANDLE, BLK

KITS PROVIDED

ITEM	QTY	PART NO	DESCRIPTION
16	1	K-41	41 SER HARDWARE KIT

① ATTACH SUPPORT, CENTER BRACKET & "L" SUPPORT STRAPS TOGETHER.

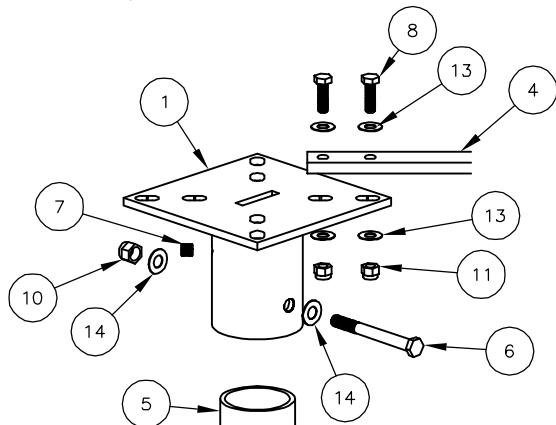

② ATTACH HOOPS TO STEP 1.

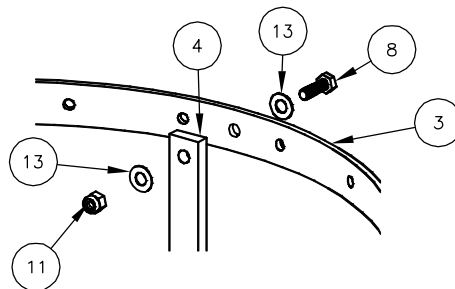

③ ATTACH SLATS TO STEP 2.

