

LETTERING LAYOUT
 BOTTLES & CANS (20 GAL)
 TRASH (32 GAL)
 NEWSPAPER (20 GAL)

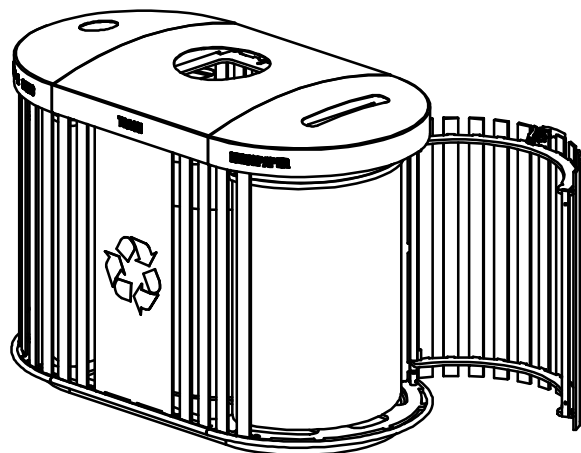
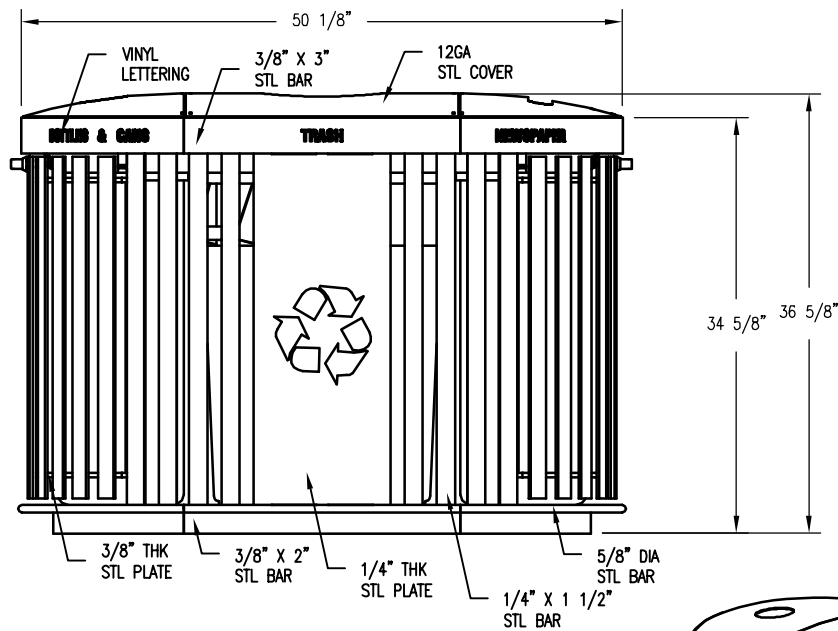

COVER NUMBERS

- 0-434-EC-10 (4" OPENING)
- 0-434-MC-12 (10" OPENING)
- 0-434-EC-11 (2" X 12" OPENING)

NOTES

- 1.) ALL STL. MEMBERS COATED W/ ZINC RICH EPOXY THEN FINISHED W/ POLYESTER POWDER COATING.
- 2.) 1/2" X 3 3/4" EXPANSION ANCHOR BOLTS PROVIDED (QTY 4).
- 3.) ENDS OF RECYCLING UNIT HINGE FOR REMOVAL OF LINERS.



RECYCLING UNIT

DATE DRAWN : 10/3/11
 DRAWN BY : JSB
 DATE REV. : 00/00/00
 REV. BY : XXX

REV.
 A

DRAWING
 NUMBER

434-72-0001

SHEET
 1 OF 2

NOTE:

- 1.) RECEPTACLE SHIPPED FULLY ASSEMBLED.
- 2.) MOUNT AND ANCHOR AS SPECIFIED.

TOOLS REQ'D

- 3/4" WRENCH
- 1/2" MASONRY DRILL BIT
- DRILL

PARTS LIST

ITEM	QTY	PART NO	DESCRIPTION
1	1	0-434-72-0001	72 GAL RECYCLING RECEPT ASSEMBLY
2	1	49-32	32 GAL PL LINER W/ HANDLE, BLK
3	2	49-20H	20 GAL HALF ROUND LINER (ANDURAN CO)

KITS PROVIDED

ITEM	QTY	PART NO	DESCRIPTION
4	1	K-ANC0860-4	1/2" X 3 3/4" SS ANCHOR KIT (4PC)

