

NOTES:

- 1.) ALL STL. MEMBERS COATED W/ ZINC RICH EPOXY THEN FINISHED W/ POLYESTER POWDER COATING.
- 2.) 1/2" X 3 3/4" SS EXPANSION ANCHOR BOLTS PROVIDED.



TABLE

DATE DRAWN : 11/10/14
 DRAWN BY : RDH
 DATE REV. :
 REV. BY :

REV.
 A

DRAWING
 NUMBER

482-42

SHEET
 1 OF 2

NOTES:

- 1.) DURING ASSEMBLY PROCEDURE;
DO NOT COMPLETELY TIGHTEN HARDWARE.
- 2.) THE ACTUAL PARTS WILL NOT BE NUMBERED.
NUMBERS ONLY APPLY TO DRAWING.
- 3.) UPON COMPLETION OF ASSEMBLY SQUARE
ALL COMPONENTS THEN TIGHTEN ALL HARDWARE.
- 4.) MOUNT AND ANCHOR AS SPECIFIED.

TOOLS REQ'D

- 3/4" WRENCH
- 9/16" WRENCH
- 1/2" MASONRY DRILL BIT
DRILL

PARTS LIST

ITEM	QTY	PART NO	DESCRIPTION
1	1	0-482-00-02	STL TABLE FRAME, BOTTOM
2	1	0-482-00-03	TABLE FRAME, TOP
3	1	0-482-42-01	42" DIA STL TABLE TOP
4	4	1-11-028	3/8" X 1" SS CGE BOLT
5	4	1-11-071	1/2" X 1 1/4" SS CGE BOLT
6	4	1-20-007	3/8" SS NYLON LOCKNUT
7	4	1-20-015	1/2" SS NYLON LOCKNUT
8	4	1-22-015	1/2" SS FLAT WASHER
9	4	1-22-024	3/8" SS FLAT WASHER

KITS PROVIDED

ITEM	QTY	PART NO	DESCRIPTION
10	1	K-ANC0860-4	1/2" X 3 3/4" SS ANCHOR KIT (4PC)
11	1	K-CG0616-4L	3/8" CGE BOLT HARDWARE KIT (4PC)
12	1	K-CG0820-4L	1/2" CGE BOLT HARDWARE KIT (4PC)

1 ATTACH TOP TABLE FRAME TO
BOTTOM TABLE FRAME.

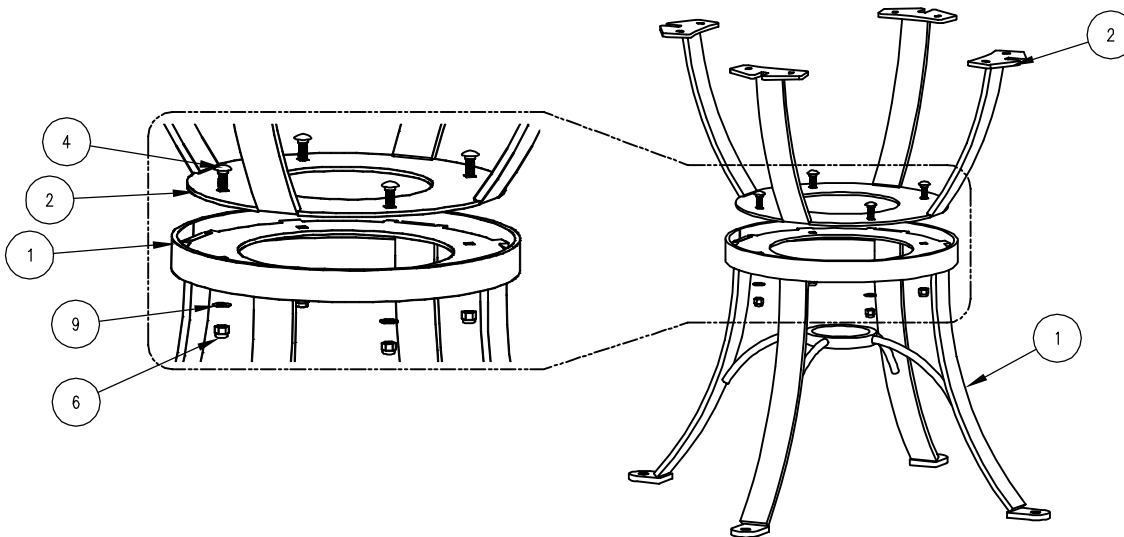

2 ATTACH TABLE TOP TO FRAME.

