

ANCHORING DETAIL

NOTES

- 1.) 1/4" X 1 1/2" HAMMERSET ANCHORS AND 1 1/4" PIPE CLAMS PROVIDED (4 - PCS)

FINISH OPTIONS:

- ALL STL. MEMBERS COATED W/ ZINC RICH EPOXY THEN FINISHED W/ POLYESTER POWDER COATING.
- HOT DIP GALV. AFTER FABRICATION.

SLAT OPTIONS

- "CEDAR" RECYCLED PLASTIC
- "GREY" RECYCLED PLASTIC
- "REDWOOD" RECYCLED PLASTIC
- "WALNUT" RECYCLED PLASTIC
- OTHER _____

DuMor, inc.
P.O. Box 142 Mifflintown, PA 17059-0142

SCALE :	NONE
DATE DRAWN :	3/22/94
DRAWN BY :	CDC
DATE REV. :	10/27/11
REV. BY :	RDH

TITLE :	PICNIC TABLE		
REV.	H	DRAWING NUMBER	71-68-1 PL
			SHEET 1 OF 2

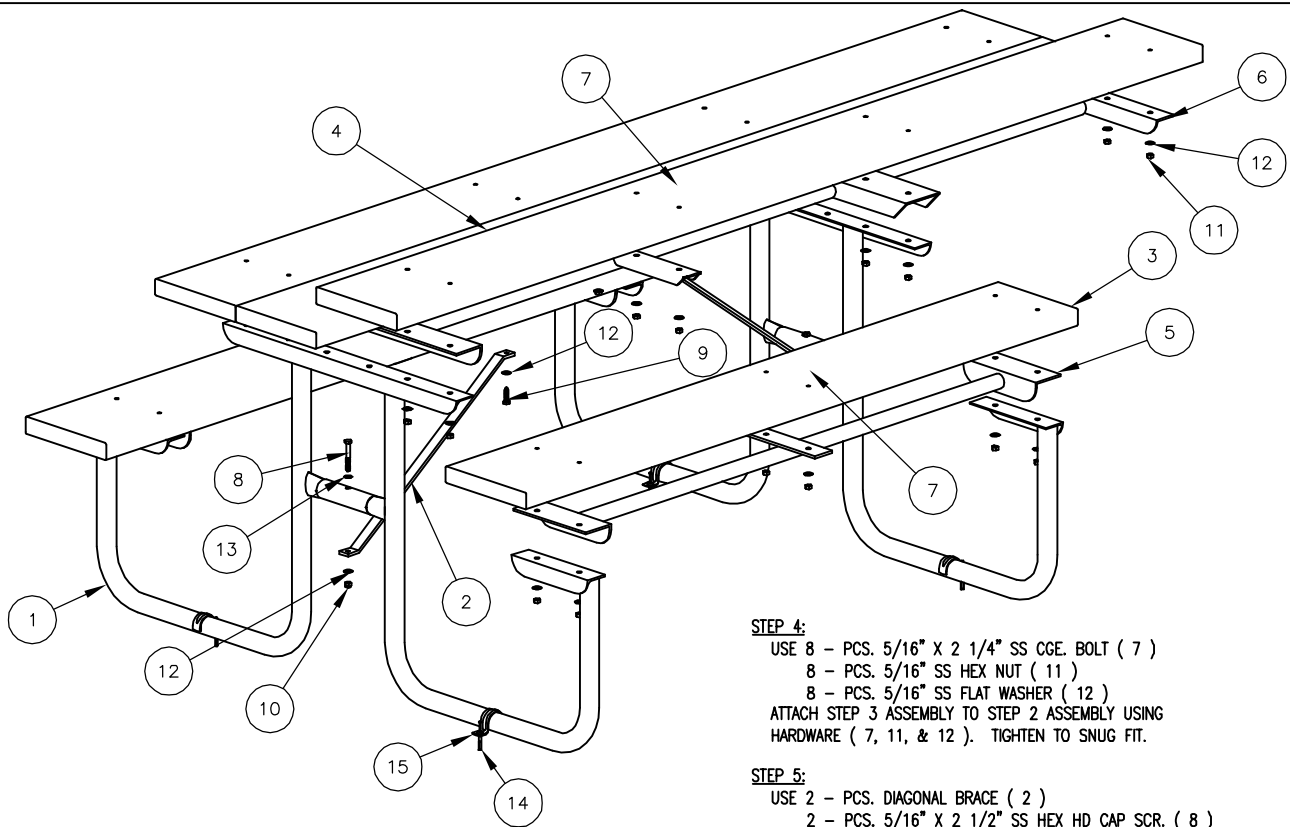

NOTE:

- 1.) DURING ASSEMBLY PROCEDURE; DO NOT COMPLETELY TIGHTEN HARDWARE.
- 2.) THE ACTUAL PARTS WILL NOT BE NUMBERED; NUMBERS ONLY APPLY TO DRAWING.
- 3.) SEE SPEC. SHEET 1 FOR MOUNTING DETAILS.

STEP 1:

USE 3 - PCS. 2" X 10" X 95" PLASTIC SLATS (4)
 1 - PC. TABLE TOP BRACE, HANDICAPPED (6)
 12 - PCS. 5/16" X 2 1/4" SS CGE. BOLT (7)
 12 - PCS. 5/16" SS HEX NUT (11)
 12 - PCS. 5/16" SS FLAT WASHER (12)
 ATTACH 2" X 10" X 95" PLASTIC SLATS (4) TO CENTER AND TO END MARKED "A" OF TABLE TOP BRACE, HANDICAPPED (6) USING HARDWARE (7, 11, & 12). TIGHTEN TO SNUG FIT. REPEAT UNTIL ALL SLATS ARE ATTACHED.

STEP 2:

USE 2 - PCS. END SUPPORT FRAME (1)
 12 - PCS. 5/16" X 2 1/4" SS CGE. BOLT (7)
 12 - PCS. 5/16" SS HEX NUT (11)
 12 - PCS. 5/16" SS FLAT WASHER (12)
 ATTACH END SUPPORT FRAME (1) TO STEP 1 ASSEMBLY USING HARDWARE (7, 11, & 12). TIGHTEN TO SNUG FIT.

STEP 3:

USE 2 - PCS. 2" X 10" X 65" PLASTIC SLATS (3)
 2 - PCS. 6" SEAT BRACE (5)
 4 - PCS. 5/16" X 2 1/4" SS CGE. BOLT (7)
 4 - PCS. 5/16" SS HEX NUT (11)
 4 - PCS. 5/16" SS FLAT WASHER (12)
 ATTACH 2" X 10" X 65" PLASTIC SLATS (3) TO CENTER OF 6" SEAT BRACE (5) USING HARDWARE (7, 11, & 12). TIGHTEN TO SNUG FIT.

STEP 4:

USE 8 - PCS. 5/16" X 2 1/4" SS CGE. BOLT (7)
 8 - PCS. 5/16" SS HEX NUT (11)
 8 - PCS. 5/16" SS FLAT WASHER (12)
 ATTACH STEP 3 ASSEMBLY TO STEP 2 ASSEMBLY USING HARDWARE (7, 11, & 12). TIGHTEN TO SNUG FIT.

STEP 5:

USE 2 - PCS. DIAGONAL BRACE (2)
 2 - PCS. 5/16" X 2 1/2" SS HEX HD CAP SCR. (8)
 2 - PCS. 5/16" X 1 1/4" SS HEX HD LAG SCR. (9)
 2 - PCS. 5/16" SS NYLON LOCK NUT (10)
 4 - PCS. 5/16" SS FLAT WASHER (12)
 2 - PCS. 3/8" ID X 5/8" OD RUBBER WASHER (13)
 SQUARE STEP 4 ASSEMBLY THEN ATTACH DIAGONAL BRACE (2) USING HARDWARE (8, 9, 10, 12, & 13). NO PILOT HOLES FOR 5/16" X 1 1/4" SS HEX HD LAG SCR. (9).

STEP 6:

UPON COMPLETION OF TABLE ASSEMBLY TIGHTEN ALL HARDWARE.

STEP 7:

4 - PCS. 1/4" X 1 1/2" HAMMERSET ANCHORS (14)
 4 - PCS. 1 1/4" RIGID PIPE CLAMP (15)
 PLACE TABLE IN SITE LOCATION DESIRED. PLACE 1 1/4" RIGID PIPE CLAMP IN CENTER OF TABLE LEGS. MARK HOLES AND MOVE 1 1/4" RIGID PIPE CLAMPS. DRILL 1/4" DIA HOLE IN CONCRETE AT MARKED HOLE LOCATIONS APPROX. 2" DEEP. BLOW OUT DUST IN DRILLED HOLES. PLACE 1 1/4" RIGID PIPE CLAMPS IN OVER TABLE LEGS AND IN LINE WITH DRILLED HOLES. PLACE 1/4" X 1 1/2" HAMMERSET ANCHORS IN HOLES AND DRIVE IN WITH HAMMER.

ITEM	QTY	PART NO	DESCRIPTION
1	2	0-71-00-02	END SUPPORT FRAME
2	2	0-71-00-03	DIAGONAL BRACE
3	2	0-71-68-1PL-1	2" X 10" X 65" PLASTIC SLAT
4	3	0-71-68-1PL-2	2" X 10" X 95" PLASTIC SLAT
5	2	0-77-60-14	6" SEAT BRACE
6	1	0-77-68-1-15	TABLE TOP BRACE, HANDICAPPED
7	36	1-11-062	5/16" X 2 1/4" SS CGE BOLT
8	2	1-12-079	5/16" X 2 1/2" SS HEX HD CAP SCR
9	2	1-13-001	5/16" X 1 1/4" SS HEX HD LAG SCR
10	2	1-20-016	5/16" SS NYLON LOCKNUT
11	36	1-21-015	5/16" SS HEX NUT
12	40	1-22-017	5/16" SS FLAT WASHER
13	2	1-22-018	3/8" ID X 5/8" OD RUBBER WASHER
14	4	1-17-021	1/4" X 1 1/2" SS HAMMERSET ANCHOR
15	4	5-48-491	1 1/4" RIGID PIPE CLAMP, 3/8" DIA HOLE, PLTD

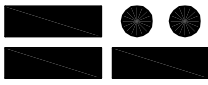

DuMor, inc.
P.O. Box 142 Mifflintown, PA 17059-0142

SCALE : NONE

TITLE : PICNIC TABLE ASSEMBLY

DATE DRAWN : 3/22/94

DRAWN BY : JSB

REV. H

DATE REV. : 10/27/11

REV. BY : RDH

DRAWING NUMBER 71-68-1 PL

SHEET 2 OF 2