

\* □ S-2 SURFACE \*  
( SEE NOTES )

**SLAT OPTIONS**

- "CEDAR" RECYCLED PLASTIC
- "GREY" RECYCLED PLASTIC
- "REDWOOD" RECYCLED PLASTIC
- "WALNUT" RECYCLED PLASTIC
- OTHER \_\_\_\_\_

**NOTES**

- 1.) ALL STL. MEMBERS COATED W/ ZINC RICH EPOXY THEN FINISHED W/ POLYESTER POWDER COATING.
  - 2.) 1/2" X 3 3/4" EXPANSION ANCHOR BOLTS PROVIDED FOR OPTIONS S-2 AND S-4.
- \* UPCHARGE APPLIES TO SUPPORT OPTION, CONSULT YOUR LOCAL REPRESENTATIVE.

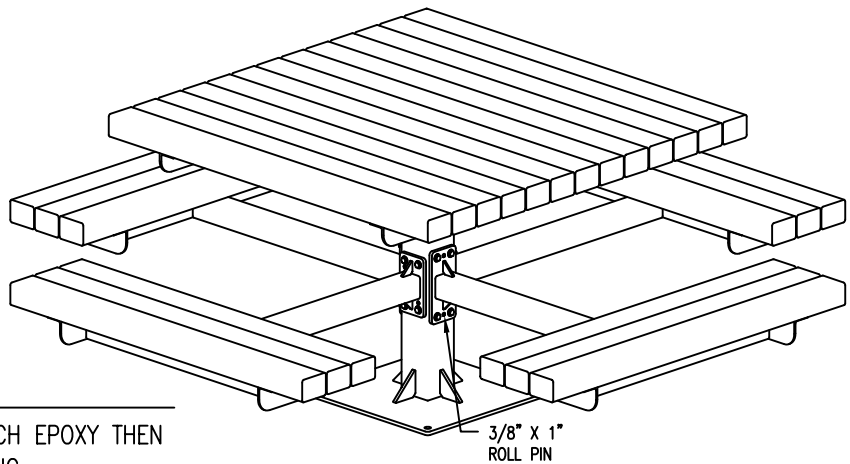

W/ 4 SEATS

- 76-34PL ( 3" x 4" )
- 76-44PL ( 4" x 4" )

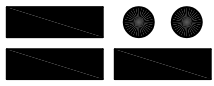
 <b>DuMor, inc.</b> P.O. Box 142 Mifflintown, PA 17059-0142	SCALE :	NONE	TITLE :		PEDESTAL TABLE	
	DATE DRAWN :	3/22/94	REV.	DRAWING NUMBER	76 SERIES PL-4	SHEET
	DRAWN BY :	AH	K			1 OF 2
	DATE REV. :	12/16/11				
	REV. BY :	ESS				

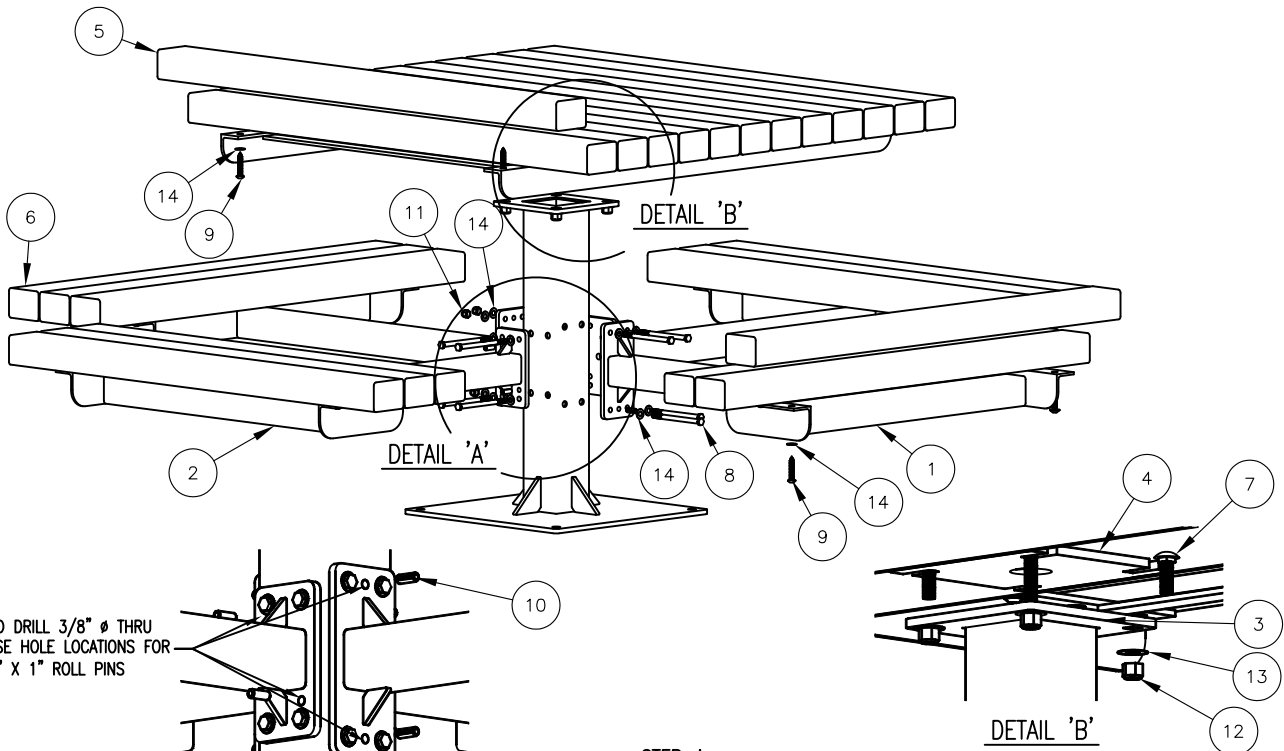

FIELD DRILL 3/8" Ø THRU THESE HOLE LOCATIONS FOR 3/8" X 1" ROLL PINS

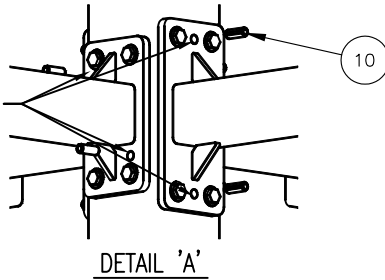

DETAIL 'A'

**NOTE:**

- 1.) DURING ASSEMBLY PROCEDURE; DO NOT COMPLETELY TIGHTEN HARDWARE.
- 2.) THE ACTUAL PARTS WILL NOT BE NUMBERED: NUMBERS ONLY APPLY TO DRAWING.
- 3.) SEE SPEC. SHEET 1 FOR MOUNTING OPTION.

**STEP 4:**

- USE 13 - PCS. 3" X 4" X 47" PLASTIC TABLE SLAT ( 5 )
  - 9 - PCS. 3" X 4" X 43" PLASTIC SEAT SLAT ( 6 )
  - 44 - PCS. 3/8" X 2" SS. BTN. SKT. HD. LAG SCR. ( 9 )
  - 44 - PCS. 3/8" SS. FLAT WASHER ( 14 )
- ATTACH 3" X 4" X 47" TABLE SLATS ( 5 ) AND 3" X 4" X 43" SEAT SLATS ( 6 ) TO STEP 2 ASSEMBLY USING HARDWARE ( 9 & 14 ). TIGHTEN TO SNUG FIT. REPEAT UNTIL ALL SLATS ARE ATTACHED.

**STEP 5:**

UPON COMPLETION OF TABLE ASSEMBLY SQUARE ALL COMPONENTS THEN TIGHTEN ALL HARDWARE.

**STEP 6:**

MOUNT AND ANCHOR AS SPECIFIED.

**STEP 7:**

USE 8 - PCS. 3/8" X 1" S.STL. ROLL PIN ( 10 )  
BE SURE SEAT IS LEVEL. FIELD DRILL CTR POST FOR SURFACE MOUNT ( 3 ) WITH 3/8" DRILL BIT AT SEAT SUPPORT ARMS ( 1 & 2 ) OPEN HOLE LOCATIONS. SEE DETAILS 'A' AND 'B'. DRIVE IN 3/8" X 1" ROLL PIN ( 10 ).

**STEP 1:**

- USE 1 - PC. CTR. POST FOR SURFACE MOUNT, ( 3 )
  - 1 - PC. TABLE TOP FRAME ( 4 )
  - 4 - PCS. 1/2" X 1 1/2" SS. CGE. BOLT ( 7 )
  - 4 - PCS. 1/2" SS. NYLON LOCK NUT ( 12 )
  - 4 - PCS. 1/2" SS. FLAT WASHER ( 13 )
- ATTACH TABLE TOP FRAME ( 4 ) TO CTR. POST FOR SURFACE MOUNT, ( 3 ) USING HARDWARE ( 7, 12, & 13 ). TIGHTEN TO SNUG FIT.

**STEP 2:**

- USE 2 - PCS. SEAT SUPPORT ARM W/ 8" PLATE ( 1 )
  - 4 - PCS. 3/8" X 5 1/2" SS. HEX HD. CAP SCR. ( 8 )
  - 4 - PCS. 3/8" SS. NYLON LOCK NUT ( 11 )
  - 8 - PCS. 3/8" SS. FLAT WASHER ( 14 )
- ATTACH SEAT SUPPORT ARM W/ 8" PLATE ( 1 ) TO STEP 1 ASSEMBLY USING HARDWARE ( 8, 11, & 14 ). TIGHTEN TO SNUG FIT.

**STEP 3:**

- USE 2 - PCS. SEAT SUPPORT ARM W/ 6 1/2" PLATE ( 2 )
  - 4 - PCS. 3/8" X 5 1/2" SS. HEX HD. CAP SCR. ( 8 )
  - 4 - PCS. 3/8" SS. NYLON LOCK NUT ( 11 )
  - 8 - PCS. 3/8" SS. FLAT WASHER ( 14 )
- ATTACH SEAT SUPPORT ARM W/ 8" PLATE ( 2 ) TO STEP 1 ASSEMBLY USING HARDWARE ( 8, 11, & 14 ). TIGHTEN TO SNUG FIT.

ITEM	QTY	PART NO	DESCRIPTION
1	2	0-76-00-05	SEAT SUPPORT ARM W/8" PLATE
2	2	0-76-00-05A	SEAT SUPPORT ARM W/6 1/2" PLATE
3	1	0-76-00-06/S-2	CTR POST FOR SURFACE MOUNT
4	1	0-76-00-07	STL TABLE TOP FRAME
5	13	0-76-30PL-01	3" X 4" X 47" PLASTIC TOP SLAT
6	12	0-76-30PL-02	3" X 4" X 43" PLASTIC SEAT SLAT
7	4	1-11-042	1/2" X 1 1/2" SS CGE BOLT
8	8	1-12-039	3/8" X 5 1/2" SS HEX HD CAP SCR
9	50	1-13-016	3/8" X 2" SS BTN SKT HD LAG SCR
10	8	1-14-003	3/8" X 1" S.STL. ROLL PIN
11	8	1-20-007	3/8" SS NYLON LOCKNUT
12	4	1-20-015	1/2" SS NYLON LOCKNUT
13	4	1-22-015	1/2" SS FLAT WASHER
14	66	1-22-024	3/8" SS FLAT WASHER

**DuMor, inc.**  
P.O. Box 142 Mifflintown, PA 17059-0142

SCALE : NONE  
DATE DRAWN : 3/24/94  
DRAWN BY : AH  
DATE REV. : 12/16/11  
REV. BY : ESS

TITLE : PEDESTAL TABLE ASSEMBLY  
REV. K  
DRAWING NUMBER 76 SERIES PL-4  
SHEET 2 OF 2