

SLAT OPTIONS

- "CEDAR" RECYCLED PLASTIC
- "GREY" RECYCLED PLASTIC
- "REDWOOD" RECYCLED PLASTIC
- "WALNUT" RECYCLED PLASTIC
- OTHER _____

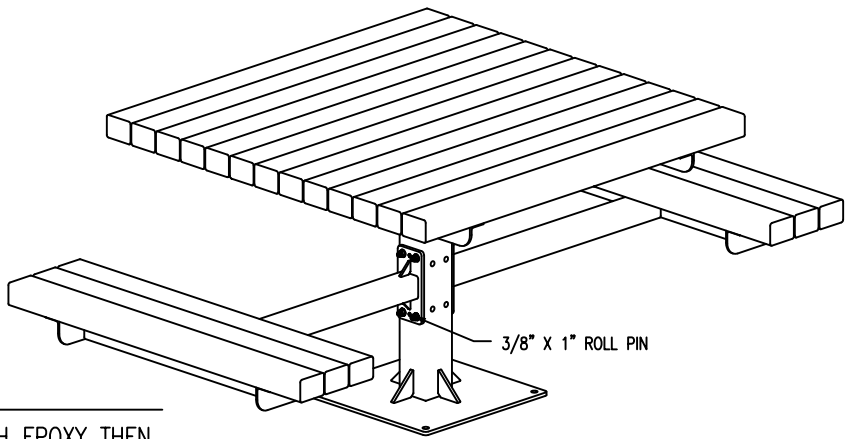

NOTES

- 1.) ALL STL. MEMBERS COATED W/ ZINC RICH EPOXY THEN FINISHED W/ POLYESTER POWDER COATING.
 - 2.) 1/2" X 3 3/4" EXPANSION ANCHOR BOLTS PROVIDED FOR OPTIONS S-2 AND S-4.
- * UPCHARGE APPLIES TO SUPPORT OPTION, CONSULT YOUR LOCAL REPRESENTATIVE.

- W/ 2 SEATS
- 76-32PL (3" x 4")
 - 76-42PL (4" x 4")

DuMor, inc.
P.O. Box 142 Mifflintown, PA 17059-0142

SCALE : NONE
DATE DRAWN : 1/8/00
DRAWN BY : JSB
DATE REV. : 12/13/11
REV. BY : ESS

TITLE : PEDESTAL TABLE

REV. 1	DRAWING NUMBER 76 SERIES PL-2	SHEET 1 OF 2
--------	-------------------------------	--------------

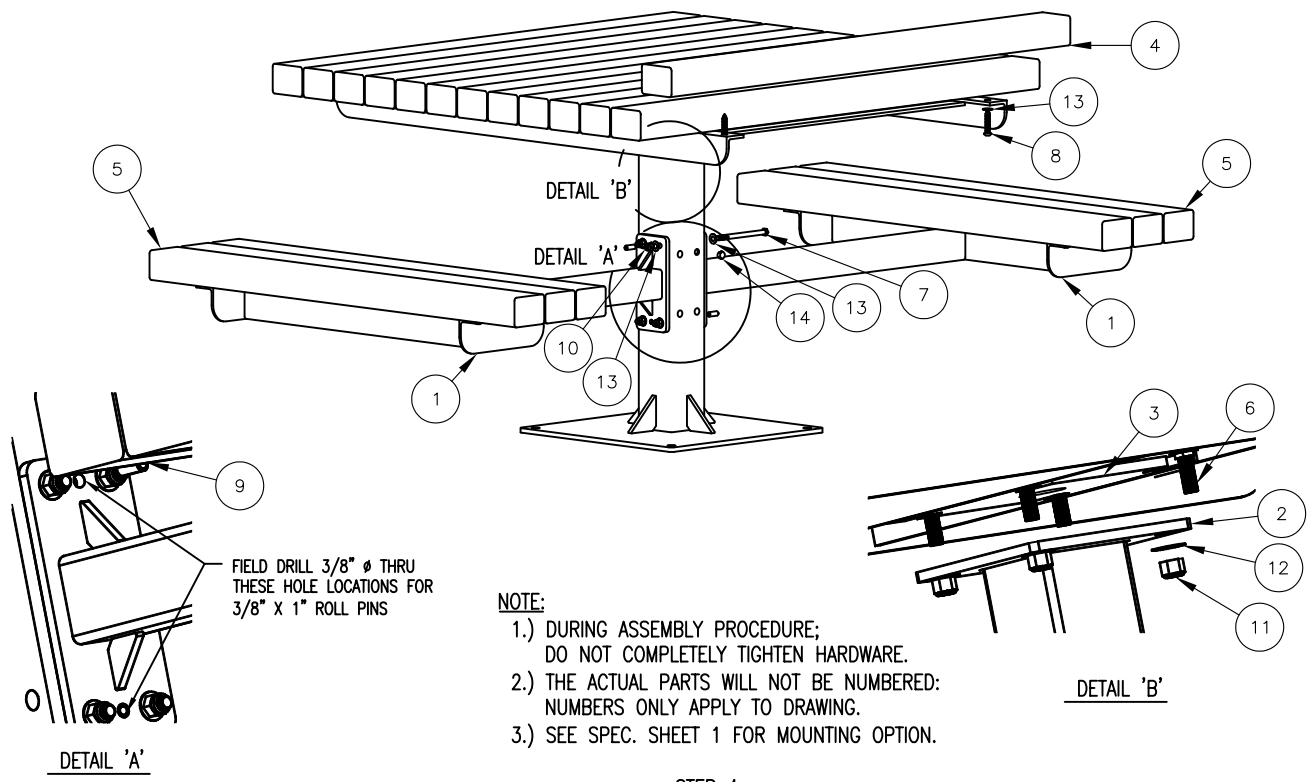

- NOTE:**
- 1.) DURING ASSEMBLY PROCEDURE; DO NOT COMPLETELY TIGHTEN HARDWARE.
 - 2.) THE ACTUAL PARTS WILL NOT BE NUMBERED: NUMBERS ONLY APPLY TO DRAWING.
 - 3.) SEE SPEC. SHEET 1 FOR MOUNTING OPTION.

STEP 1:

USE 1 - PC. CTR. POST FOR SURFACE MOUNT, (2)
 1 - PC. TABLE TOP FRAME (3)
 4 - PCS. 1/2" X 1 1/2" SS. CGE. BOLT (6)
 4 - PCS. 1/2" SS. NYLON LOCK NUT (11)
 4 - PCS. 1/2" SS. FLAT WASHER (12)

ATTACH TABLE TOP FRAME (3) TO CTR. POST FOR SURFACE MOUNT, (2) USING HARDWARE (6, 11, & 12). TIGHTEN TO SNUG FIT.

STEP 2:

USE 2 - PCS. SEAT SUPPORT ARM W/ 8" PLATE (1)
 4 - PCS. 3/8" X 5 1/2" SS. HEX HD. CAP SCR. (7)
 4 - PCS. 3/8" SS. NYLON LOCK NUT (10)
 8 - PCS. 3/8" SS. FLAT WASHER (13)

ATTACH SEAT SUPPORT ARM W/ 8" PLATE (1) TO STEP 1 ASSEMBLY USING HARDWARE (7, 10, & 13). TIGHTEN TO SNUG FIT.

STEP 3:

USE 13 - PCS. 3" X 4" X 47" PLASTIC TABLE SLAT (4)
 6 - PCS. 3" X 4" X 43" PLASTIC SEAT SLAT (5)
 38 - PCS. 3/8" X 2" SS. BTN. SKT. HD. LAG SCR. (8)
 38 - PCS. 3/8" SS. FLAT WASHER (13)

ATTACH 3" X 4" X 47" TABLE SLATS (4) AND 3" X 4" X 43" SEAT SLATS (5) TO STEP 2 ASSEMBLY USING HARDWARE (8 & 13). TIGHTEN TO SNUG FIT. REPEAT UNTIL ALL SLATS ARE ATTACHED.

STEP 4:

USE 8 - PCS. BLACK PLASTIC PLUG (14)
 INSERT BLACK PLASTIC PLUG INTO REMAINING HOLES.

STEP 5:

UPON COMPLETION OF TABLE ASSEMBLY SQUARE ALL COMPONENTS THEN TIGHTEN ALL HARDWARE.

STEP 6:

MOUNT AND ANCHOR AS SPECIFIED.

STEP 7:

USE 4 - PCS. 3/8" X 1" S.STL. ROLL PIN (9)
 BE SURE SEAT IS LEVEL. FIELD DRILL CTR POST FOR SURFACE MOUNT (2) WITH 3/8" DRILL BIT AT SEAT SUPPORT ARM W/ 8" PLATE (1) OPEN HOLE LOCATIONS. SEE DETAILS 'A' AND 'B'. DRIVE IN 3/8" X 1" ROLL PIN (9).

ITEM	QTY	PART NO	DESCRIPTION
1	2	0-76-00-05	SEAT SUPPORT ARM W/8" PLATE
2	1	0-76-00-06/S-2	CTR POST FOR SURFACE MOUNT
3	1	0-76-00-07	STL TABLE TOP FRAME
4	13	0-76-30PL-01	3" X 4" X 47" PLASTIC TOP SLAT
5	6	0-76-30PL-02	3" X 4" X 43" PLASTIC SEAT SLAT
6	4	1-11-042	1/2" X 1 1/2" SS CGE BOLT
7	4	1-12-039	3/8" X 5 1/2" SS HEX HD CAP SCR
8	38	1-13-016	3/8" X 2" SS BTN SKT HD LAG SCR
9	4	1-14-003	3/8" X 1" S.STL. ROLL PIN
10	4	1-20-007	3/8" SS NYLON LOCKNUT
11	4	1-20-015	1/2" SS NYLON LOCKNUT
12	4	1-22-015	1/2" SS FLAT WASHER
13	46	1-22-024	3/8" SS FLAT WASHER
14	8	5-48-059	BLACK PLASTIC PLUG

DuMor, inc.
 P.O. Box 142 Mifflintown, PA 17059-0142

SCALE : NONE
 DATE DRAWN : 1/8/00
 DRAWN BY : JSB
 DATE REV. : 12/13/11
 REV. BY : ESS

TITLE : PEDESTAL TABLE ASSEMBLY

REV. 1	DRAWING NUMBER 76 SERIES PL-2	SHEET 2 OF 2
--------	-------------------------------	--------------