

2" X 3" (NOM.) SLATS
(SEE SLAT OPTIONS)

3/8" X 3 1/2" S.STL.
CAP SCR. W/ NUT

3/8" X 1"
STL. BAR

1/4" X 1 1/4"
S.STL. LAG SCR.

Ø 9 5/8"
OPENING

5/16" X 1" S.STL. HEX HD.
CAP SCR. W/ S.STL. WASHER
AND NYLON LOCKNUT

3/16" X 6" SQ.
STL. PLATE

3/16" X 1 1/4"
STL. BAR

POLYETHYLENE COVER

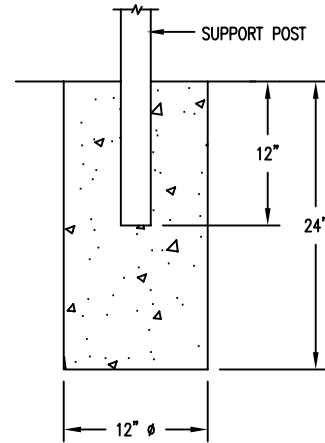
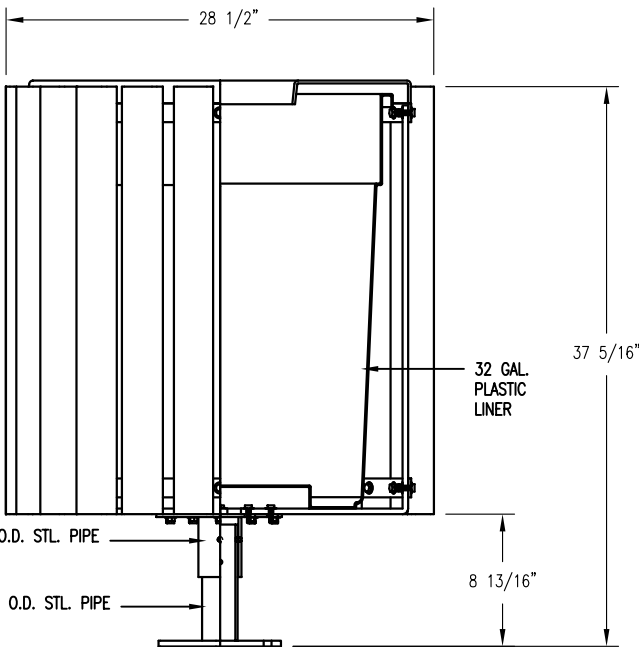
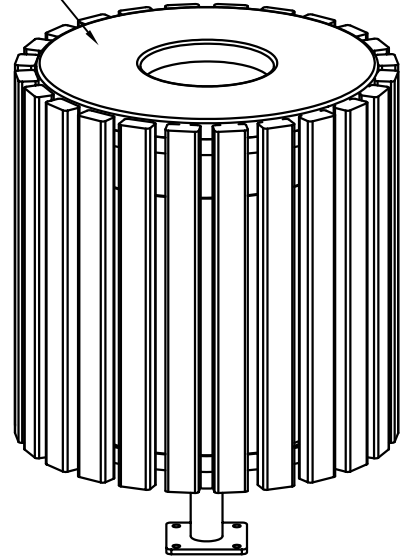

S-1 EMBEDMENT

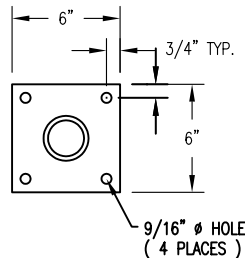

S-2 SURFACE

SLAT OPTIONS

- "CEDAR" RECYCLED PLASTIC
- "GREY" RECYCLED PLASTIC
- "REDWOOD" RECYCLED PLASTIC
- "WALNUT" RECYCLED PLASTIC
- OTHER _____

NOTES

- 1.) ALL STL. MEMBERS COATED W/ ZINC RICH EPOXY THEN FINISHED W/ BLACK POLYESTER POWDER COATING
- 2.) 1/2" X 3 3/4" EXPANSION ANCHOR BOLTS PROVIDED FOR S-2.

DuMor, inc.
P.O. Box 142 Mifflintown, PA 17059-0142

SCALE : NONE
DATE DRAWN : 7/17/03
DRAWN BY : AH
DATE REV. : 10/25/11
REV. BY : ESS

TITLE : RECEPTACLE

REV. E DRAWING NUMBER 41-32PL/46-00

SHEET 1 OF 2

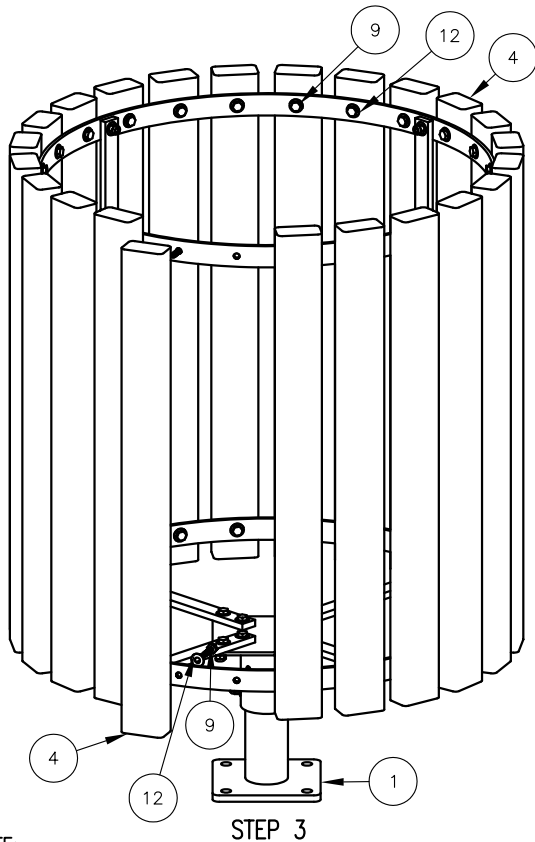

STEP 3

NOTE:

- 1.) DURING ASSEMBLY PROCEDURE:
DO NOT COMPLETELY TIGHTEN HARDWARE.
- 2.) THE ACTUAL PARTS WILL NOT BE NUMBERED:
NUMBERS ONLY APPLY TO DRAWING.
- 3.) SEE SPEC. SHEET 1 FOR MOUNTING OPTIONS.

STEP 1:

- USE 2 - PCS. HOOP FOR 30 GAL (3)
 4 - PCS. "L" SUPPORT STRAP FOR 30 GAL (5)
 8 - PCS. 5/16" X 1" SS. HEX HD. CAP SCR. (8)
 8 - PCS. 5/16" SS. NYLON LOCK NUT (11)
 16 - PCS. 5/16" SS. FLAT WASHER (13)
- ATTACH "L" SUPPORT STRAP (5) TO INSIDE HOOPS (3) USING HARDWARE (8, 11, & 13). TIGHTEN TO SNUG FIT.
 REPEAT UNTIL ALL "L" SUPPORT STRAPS ARE ATTACHED TO HOOPS.

STEP 2:

- USE 1 - PC. CENTER BRACKET (2)
 8 - PCS. 5/16" X 1" SS. HEX HD. CAP SCR. (8)
 8 - PCS. 5/16" SS. NYLON LOCK NUT (11)
 16 - PCS. 5/16" SS. FLAT WASHER (13)
- ATTACH CENTER BRACKET TO STEP 1 ASSEMBLY USING HARDWARE (8, 11, & 13). TIGHTEN TO SNUG FIT.

STEP 3:

- USE 24 - PCS. 2" X 3" X 28 1/2" PLASTIC SLAT (4)
 48 - PCS. 1/4" X 1 1/4" SS. HEX HD. LAG SCR. (9)
 48 - PCS. 1/4" SS. FLAT WASHER (12)
- ATTACH 2" X 3" X 28 1/2" PLASTIC SLATS (4) TO STEP 2 ASSEMBLY USING HARDWARE (9 & 12). TIGHTEN TO SNUG FIT. REPEAT UNTIL ALL SLATS ARE ATTACHED.

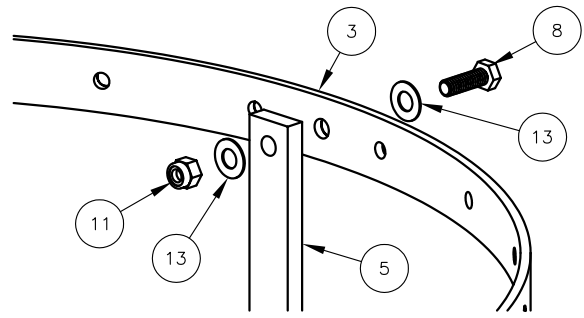

STEP 1

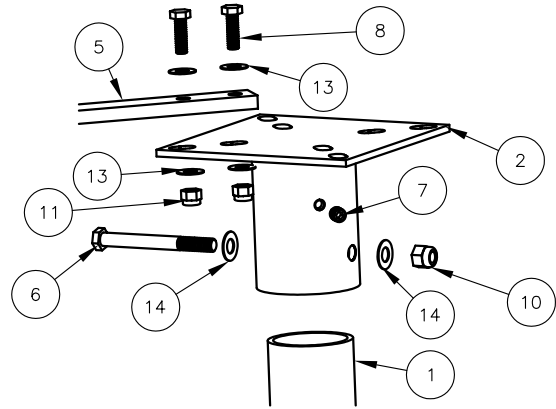

STEP 2 & STEP 5

STEP 4:

UPON COMPLETION OF BASKET ASSEMBLY SQUARE ALL COMPONENTS THEN TIGHTEN ALL HARDWARE.

STEP 5:

- USE 1 - PC. SUPPORT FOR SURFACE MOUNT (1)
 1 - PC. 3/8" X 3 1/2" SS. HEX HD. CAP SCR. (6)
 1 - PC. 3/8" SS. NYLON LOCK NUT (10)
 2 - PC. 3/8" SS. FLAT WASHER (14)
 2 - PCS. 3/8" X 3/8" SS. SKT. SET SCR. (7)
- ATTACH SURFACE MOUNT SUPPORT (1) TO STEP 4 ASSEMBLY USING HARDWARE (6, 10, 14, & 7) AND TIGHTEN ALL HARDWARE.

STEP 6:

TO ATTACH COVER, REMOVE ONE 1/4" X 1 1/4" LAG SCREW AND FASTEN OPEN END OF CABLE TO BASKET USING THE LAG REMOVED.

STEP 7:

MOUNT AND ANCHOR AS SPECIFIED.

ITEM	QTY	PART NO	DESCRIPTION
1	1	0-41-00-03/S-2	SUPPORT FOR SURFACE MOUNT
2	1	0-41-00-04	CENTER BRACKET
3	2	0-41-30-01	HOOP FOR 30 GAL
4	24	0-41-30PL-06	2" X 3" X 28 1/2" PLASTIC SLAT
5	4	0-41-30-07	"L" SUPPORT STRAP FOR 30 GAL
6	1	1-12-034	3/8" X 3 1/2" SS HEX HD CAP SCR
7	2	1-12-054	3/8" X 3/8" SS SKT SET SCR
8	16	1-12-061	5/16" X 1" SS HEX HD CAP SCR
9	48	1-13-004	1/4" X 1 1/4" SS HEX HD LAG SCR
10	1	1-20-007	3/8" SS NYLON LOCKNUT
11	16	1-20-016	5/16" SS NYLON LOCKNUT
12	48	1-22-006	1/4" SS FLAT WASHER
13	32	1-22-017	5/16" SS FLAT WASHER
14	2	1-22-024	3/8" SS FLAT WASHER



DuMor, inc.

P.O. Box 142 Mifflintown, PA 17059-0142

SCALE :

NONE

DATE DRAWN : 7/17/03

DRAWN BY : AWH

DATE REV. : 12/17/09

REV. BY : AWH

TITLE :

RECEPTACLE ASSEMBLY

REV.

DRAWING NUMBER

41-32PL/46-00

SHEET

2 OF 2