

BE SURE TO ATTACH SEAT FRAME WITH BENT STRAP ON SEAT END

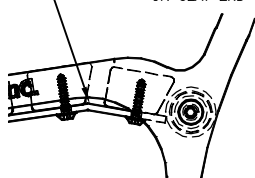

SEAT FRAME BOLTING DETAIL

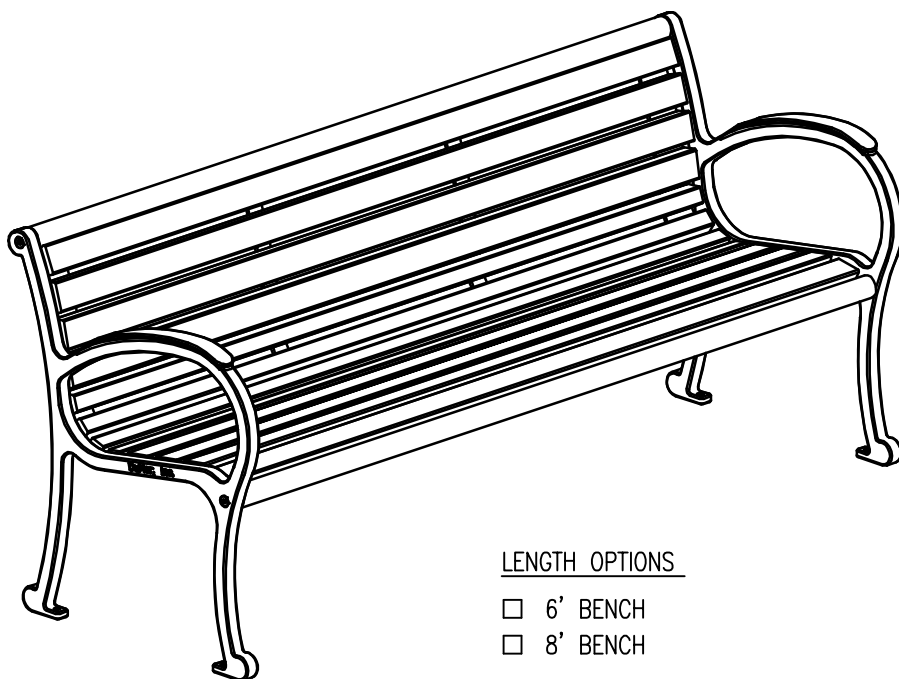

LENGTH OPTIONS

- 6' BENCH
- 8' BENCH

SLAT OPTIONS

- "CEDAR" RECYCLED PLASTIC
- "GREY" RECYCLED PLASTIC
- "REDWOOD" RECYCLED PLASTIC
- "WALNUT" RECYCLED PLASTIC
- OTHER _____

NOTES

- 1.) ALL STL. MEMBERS COATED W/ ZINC RICH EPOXY THEN FINISHED W/ POLYESTER POWDER COATING.
- 2.) 1/2" X 3 3/4" EXPANSION ANCHOR BOLTS PROVIDED.

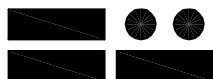

DuMor, inc.

P.O. Box 142 Mifflintown, PA 17059-0142

SCALE :	NONE
DATE DRAWN :	6/28/05
DRAWN BY :	AWH
DATE REV. :	10/26/11
REV. BY :	RDH

TITLE : BENCH

REV. D

DRAWING NUMBER 165 SERIES-PL

SHEET 1 OF 2

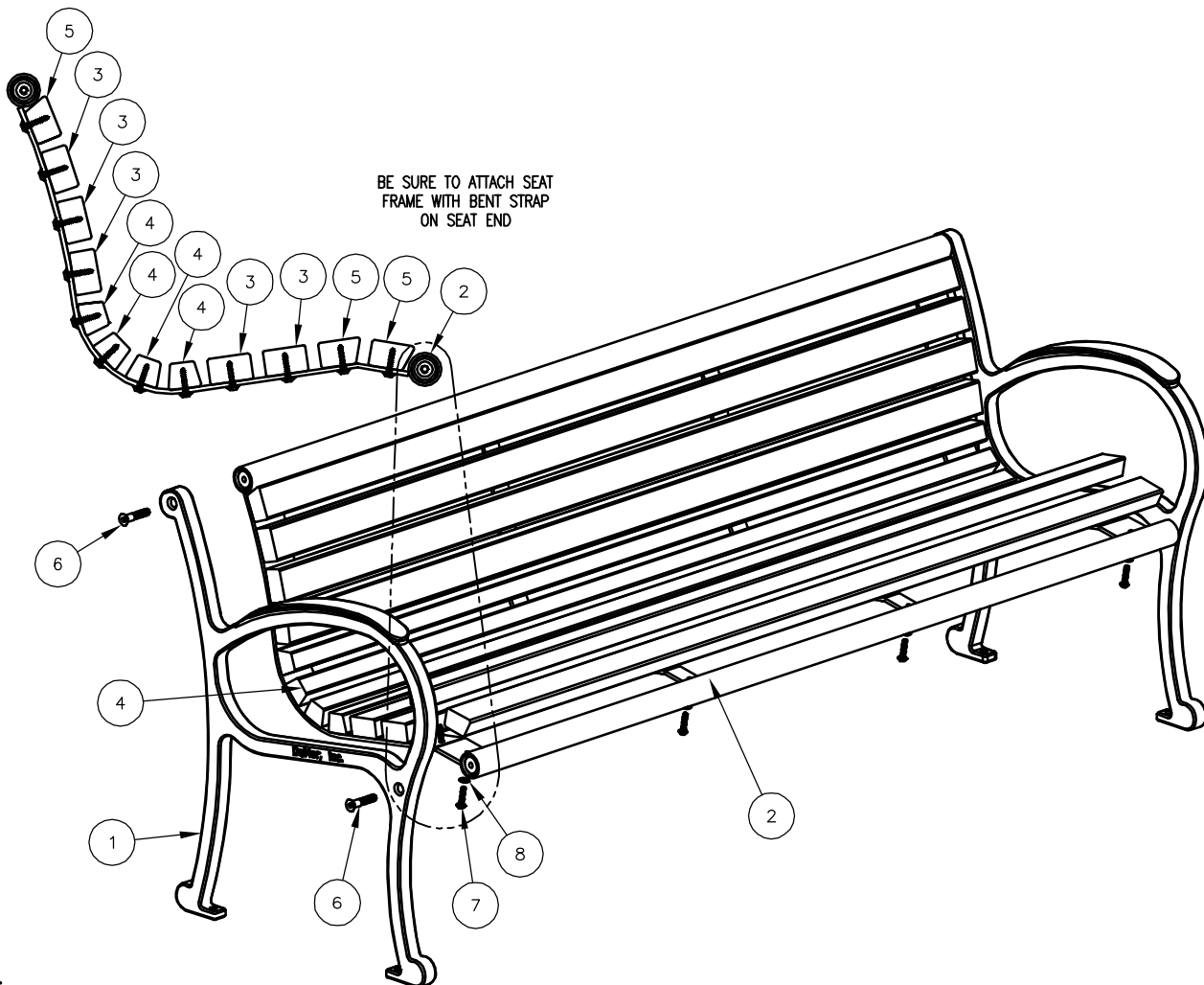

STEP 1:

USE 2 - PCS. CAST IRON BENCH SUPPORT W/ BACK (1)
 1 - PC. 6' SEAT FRAME (2)
 4 - PCS. 1/2" X 2 1/2" FLT. SKT. HD. CAP SCR. (6)
 ATTACH CAST IRON SUPPORT W/ BACK (1) TO 6' SEAT FRAME (2) USING HARDWARE (6). TIGHTEN TO SNUG FIT.

NOTE:

- 1.) DURING ASSEMBLY PROCEDURE;
DO NOT COMPLETELY TIGHTEN HARDWARE.
- 2.) THE ACTUAL PARTS WILL NOT BE NUMBERED:
NUMBERS ONLY APPLY TO DRAWING.

STEP 2:

USE 5 - PCS. 2" X 3" X 71" PLASTIC INT'R SLAT (3)
 4 - PCS. 71" PLASTIC TRAP SLAT (4)
 3 - PCS. 71" PLASTIC PROFILE SLAT (5)
 48 - PCS. 5/16" X 1 1/2" SS. BTN. SKT. HD. LAG (7)
 48 - PCS. 5/16" SS. FLAT WASHER (8)
 ATTACH SLATS (3, 4 & 5) TO STEP 1 ASSEMBLY USING HARDWARE (7 & 8). TIGHTEN TO SNUG FIT.

STEP 3:

UPON COMPLETION OF BENCH ASSEMBLY SQUARE ALL COMPONENTS THEN TIGHTEN ALL HARDWARE.

STEP 4:

MOUNT AND ANCHOR AS SPECIFIED.

ITEM	QTY	PART NO	DESCRIPTION
1	2	0-160-00-01	CAST IRON BENCH SUPPORT FOR BACKREST
2	1	0-165-60-01	6' SEAT FRAME
3	5	0-143-60PL-01	2" X 3" X 71" PLASTIC INT'R SLAT
4	4	0-165-60PL-03	71" PLASTIC TRAP SLAT
5	3	0-165-60PL-04	71" PLASTIC PROFILE SLAT
6	4	1-12-065	1/2" X 2 1/2" FLT SKT HD CAP SCR
7	48	1-13-023	5/16" X 1 1/2" SS BTN SKT HD LAG
8	48	1-22-017	5/16" SS FLAT WASHER

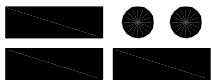
 DuMor, inc. P.O. Box 142 Mifflintown, PA 17059-0142	SCALE :	NONE	TITLE :	
	DATE DRAWN :	6/28/05	BENCH ASSEMBLY 165 SERIES-PL	
	DRAWN BY :	AWH		
	DATE REV. :	10/26/11		
REV. BY :	RDH	REV. :	D	SHEET 2 OF 2