

CUSTOM LETTERING (37 SPACES) _____

NOTES

- 1.) ALL STL. MEMBERS COATED W/ ZINC RICH EPOXY THEN FINISHED W/ POLYESTER POWDER COATING.
- 2.) 1/2" X 3 3/4" EXPANSION ANCHOR BOLTS PROVIDED.
- 3.) CUSTOM LETTERING AVAILABLE FOR RECESSED SIDE PANELS (TOTAL OF 37 SPACES).

SLAT OPTIONS

- "CEDAR" RECYCLED PLASTIC
- "GREY" RECYCLED PLASTIC
- "REDWOOD" RECYCLED PLASTIC
- "WALNUT" RECYCLED PLASTIC
- OTHER _____



DuMor, inc.
P.O. Box 142 Mifflintown, PA 17059-0142

SCALE : NONE
DATE DRAWN : 1/22/02
DRAWN BY : AH
DATE REV. : 10/25/11
REV. BY : RDH

TITLE : BENCH
REV. E
DRAWING NUMBER 57-40PL

SHEET 1 OF 2

NOTE:

- 1.) DURING ASSEMBLY PROCEDURE;
DO NOT COMPLETELY TIGHTEN HARDWARE.
- 2.) THE ACTUAL PARTS WILL NOT BE NUMBERED.
NUMBERS ONLY APPLY TO DRAWING.

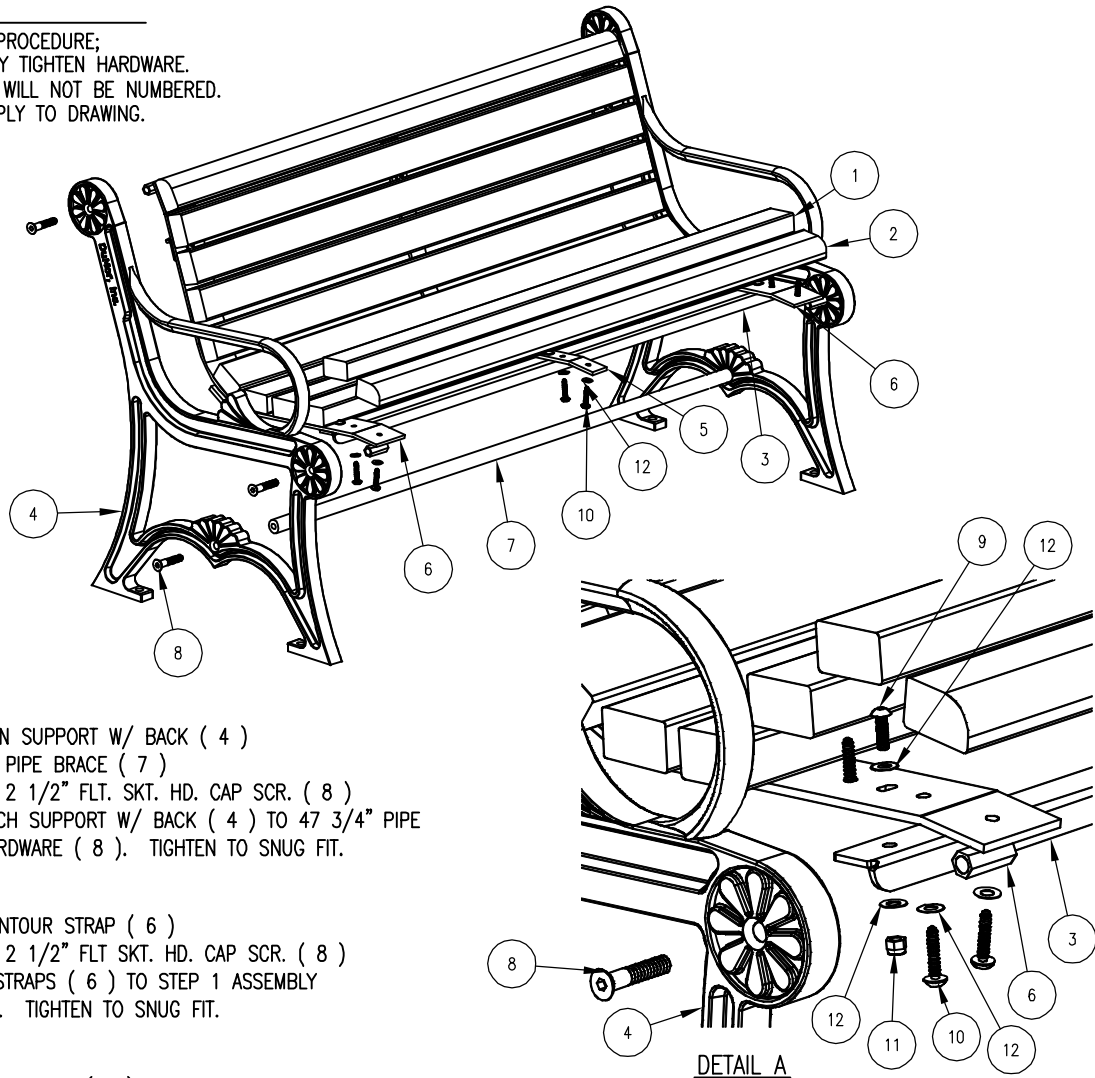

STEP 1:

USE 2 - PC. CAST IRON SUPPORT W/ BACK (4)
 1 - PC. 47 3/4" PIPE BRACE (7)
 2 - PCS. 1/2" X 2 1/2" FLT. SKT. HD. CAP SCR. (8)
 ATTACH CAST IRON BENCH SUPPORT W/ BACK (4) TO 47 3/4" PIPE BRACE (7) USING HARDWARE (8). TIGHTEN TO SNUG FIT.

STEP 2:

USE 2 - PCS. END CONTOUR STRAP (6)
 4 - PCS. 1/2" X 2 1/2" FLT SKT. HD. CAP SCR. (8)
 ATTACH END CONTOUR STRAPS (6) TO STEP 1 ASSEMBLY USING HARDWARE (8). TIGHTEN TO SNUG FIT.

STEP 3:

USE 2 - PCS. 47" SEAT BRACE (3)
 4 - PCS. 5/16" X 1" SS. BTN SKT. HD CAP SCR (9)
 4 - PCS. 5/16" SS. NYLON LOCKNUT (11)
 8 - PCS. 5/16" SS. FLAT WASHER (12)
 ATTACH 47" SEAT BRACE (3) TO STEP 2 ASSEMBLY USING HARDWARE (9, 11 & 12). TIGHTEN TO SNUG FIT.

STEP 4:

USE 1 - PC. CENTER CONTOUR STRAP (5)
 2 - PCS. 5/16" X 1" SS. BTN SKT. HD CAP SCR. (9)
 2 - PCS. 5/16" SS. NYLON LOCKNUT (11)
 4 - PCS. 5/16" SS. FLAT WASHER (12)
 ATTACH CENTER CONTOUR STRAP (5) TO STEP 3 ASSEMBLY USING HARDWARE (9, 11 & 12). TIGHTEN TO SNUG FIT.

STEP 5:

USE 9 - PCS. 2" X 3" X 47" PLASTIC INT'R SLAT (1)
 2 - PCS. 2" X 3" X 47" PLASTIC EDGE SLAT (2)
 33 - PCS. 5/16" X 1 1/2" SS. BTN. SKT. HD. LAG (10)
 33 - PCS. 5/16" SS. FLAT WASHER (12)
 ATTACH 2" X 3" X 47" PLASTIC SLATS (1 & 2) TO STEP 4 ASSEMBLY USING HARDWARE (10 & 12). TIGHTEN TO SNUG FIT.
 REPEAT UNTIL ALL SLATS ARE ATTACHED.

STEP 6:

UPON COMPLETION OF BENCH ASSEMBLY SQUARE ALL COMPONENTS THEN TIGHTEN ALL HARDWARE.

STEP 7:

MOUNT AND ANCHOR AS SPECIFIED.

ITEM	QTY	PART NO	DESCRIPTION
1	9	0-143-40PL-01	2" X 3" X 47" INTERIOR PLASTIC SLAT
2	2	0-143-40PL-02	2" X 3" X 47" PLASTIC EDGE SLAT
3	2	0-16-40-06	47" SEAT BRACE
4	2	0-57-00-02	CAST IRON BENCH SUPPORT
5	1	0-57-00-03	CENTER CONTOUR STRAP
6	2	0-57-00-05	END CONTOUR STRAP
7	1	0-57-40-04	47 3/4" PIPE BRACE
8	6	1-12-065	1/2" X 2 1/2" FLT SKT HD CAP SCR
9	6	1-12-116	5/16" X 1" SS BTN SKT HD CAP SCR
10	33	1-13-023	5/16" X 1 1/2" SS BTN SKT HD LAG
11	6	1-20-016	5/16" SS NYLON LOCKNUT
12	45	1-22-017	5/16" SS FLAT WASHER

P.O. Box 142 Mifflintown, PA 17059-0142

SCALE : NONE
 DATE DRAWN : 1/22/02
 DRAWN BY : AWH
 DATE REV. : 10/25/11
 REV. BY : RDH

TITLE : BENCH ASSEMBLY
 REV. E
 DRAWING NUMBER 57-40PL
 SHEET 2 OF 2