

LENGTH OPTIONS

- 6' BENCH
- 8' BENCH

NOTES

- 1.) ALL STL. MEMBERS COATED W/ ZINC RICH EPOXY THEN POLYESTER POWDER COATED.
- 2.) WOOD MEMBERS TRTD. W/ CLEAR PRESERVATIVE.
- 3.) 1/2" X 3 3/4" EXPANSION ANCHOR BOLTS PROVIDED.

WOOD OPTIONS

- 'C' & BTR. DOUGLAS FIR S4S EE
- IPE S4S EE
- OTHER _____



BENCH
PATENT D470-690

DATE DRAWN : 07/11/01
DRAWN BY : AWH
DATE REV. : 10/27/11
REV. BY : RDH

REV.
C

DRAWING
NUMBER

146 SERIES

SHEET
1 OF 2

NOTES:

- 1.) DURING ASSEMBLY PROCEDURE;
DO NOT COMPLETELY TIGHTEN HARDWARE.
- 2.) THE ACTUAL PARTS WILL NOT BE NUMBERED.
NUMBERS ONLY APPLY TO DRAWING.
- 3.) UPON COMPLETION OF ASSEMBLY SQUARE
ALL COMPONENTS THEN TIGHTEN ALL HARDWARE.
- 4.) MOUNT AND ANCHOR AS SPECIFIED.

TOOLS REQ'D

- 3/4" WRENCH
- 3/16" ALLEN WRENCH
- 5/16" ALLEN WRENCH
- 1/2" MASONRY DRILL BIT
DRILL

PARTS LIST

ITEM	QTY	PART NO	DESCRIPTION
1	2	0-144-00-01	CAST IRON BENCH SUPPORT W/O BACK
2	5	0-57-60-01	2" X 3" X 71" WOOD INT'R SLAT
3	2	0-57-60-02	2" X 3" X 71" WOOD EDGE SLAT
4	1	0-57-60-04	71 3/4" PIPE BRACE
5	1	0-91-00-03	CENTER STRAP
6	2	0-91-00-04	END CONTOUR STRAP
7	6	1-12-065	1/2" X 2 1/2" FLT SKT HD CAP SCR
8	21	1-13-023	5/16" X 1 1/2" SS BTN SKT HD LAG
9	21	1-22-017	5/16" SS FLAT WASHER

KITS PROVIDED

ITEM	QTY	PART NO	DESCRIPTION
10	1	K-ANC0860-4	1/2" X 3 3/4" SS ANCHOR KIT (4PC)
11	1	K-BL0524-21	5/16" LAG HARDWARE KIT (21PC)
12	1	K-FC0840-6	1/2" CAP HARDWARE KIT (6PC)

① ATTACH PIPE BRACE & END CONTOUR STRAPS TO BENCH SUPPORTS.

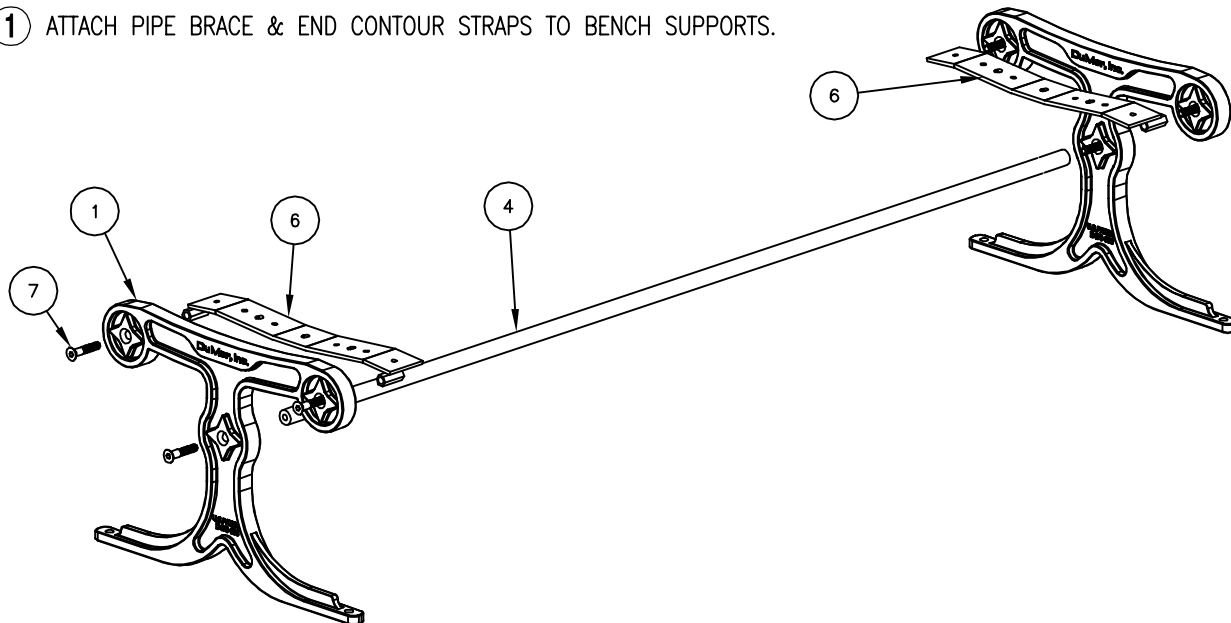

② ATTACH SLATS TO END CONTOUR STRAPS.

③ ATTACH CENTER CONTOUR STRAP TO SLATS.

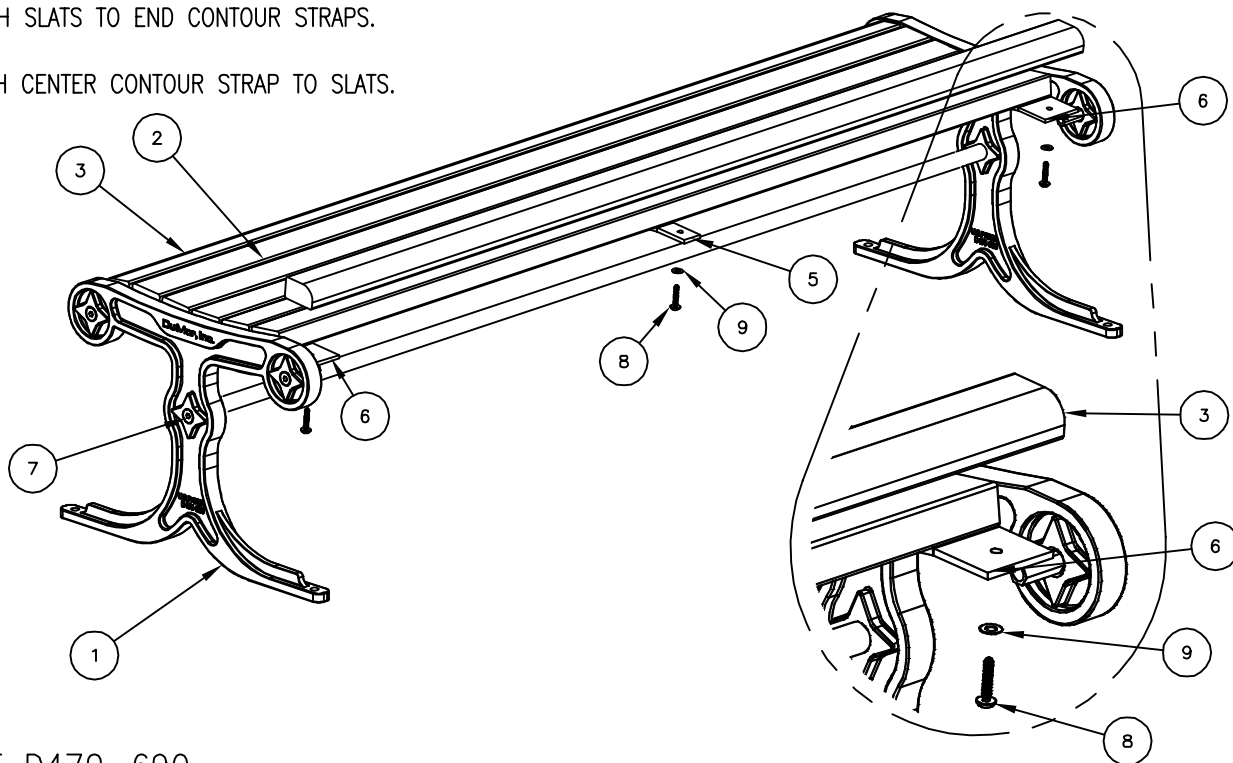

PATENT D470-690



ASSEMBLY
INSTRUCTIONS

DATE DRAWN : 07/11/01
DRAWN BY : AWH
DATE REV. : 10/27/11
REV. BY : RDH

REV.
A

DRAWING
NUMBER

146 SERIES

SHEET
2 OF 2