

WOOD OPTIONS

- 'C' & BTR. DOUGLAS FIR KD S4S EE
- IPE S4S EE
- OTHER _____

NOTES:

- 1.) ALL STL. MEMBERS COATED W/ ZINC RICH EPOXY THEN FINISHED W/ POLYESTER POWDER COATING.
- 2.) 1/2" X 1 1/2" NYLON GLIDES & 1/2" X 3 3/4" EXPANSION ANCHOR BOLTS W/ S-2 PLATES PROVIDED.
- 3.) ALL WOOD MEMBERS TREATED W/ CLEAR PRESERVATIVE.

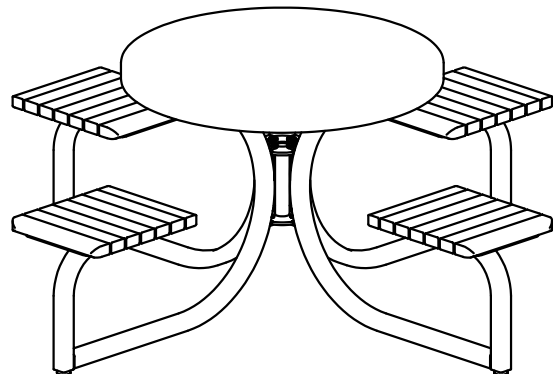

DuMor, inc.
 P.O. Box 142 Mifflintown, PA 17059-0142

SCALE : NONE

DATE DRAWN : 10/11/12

DRAWN BY : JSB

DATE REV. :

REV. BY :

TITLE : TABLE		DRAWING NUMBER 445-34	SHEET 1 OF 2
REV. A			

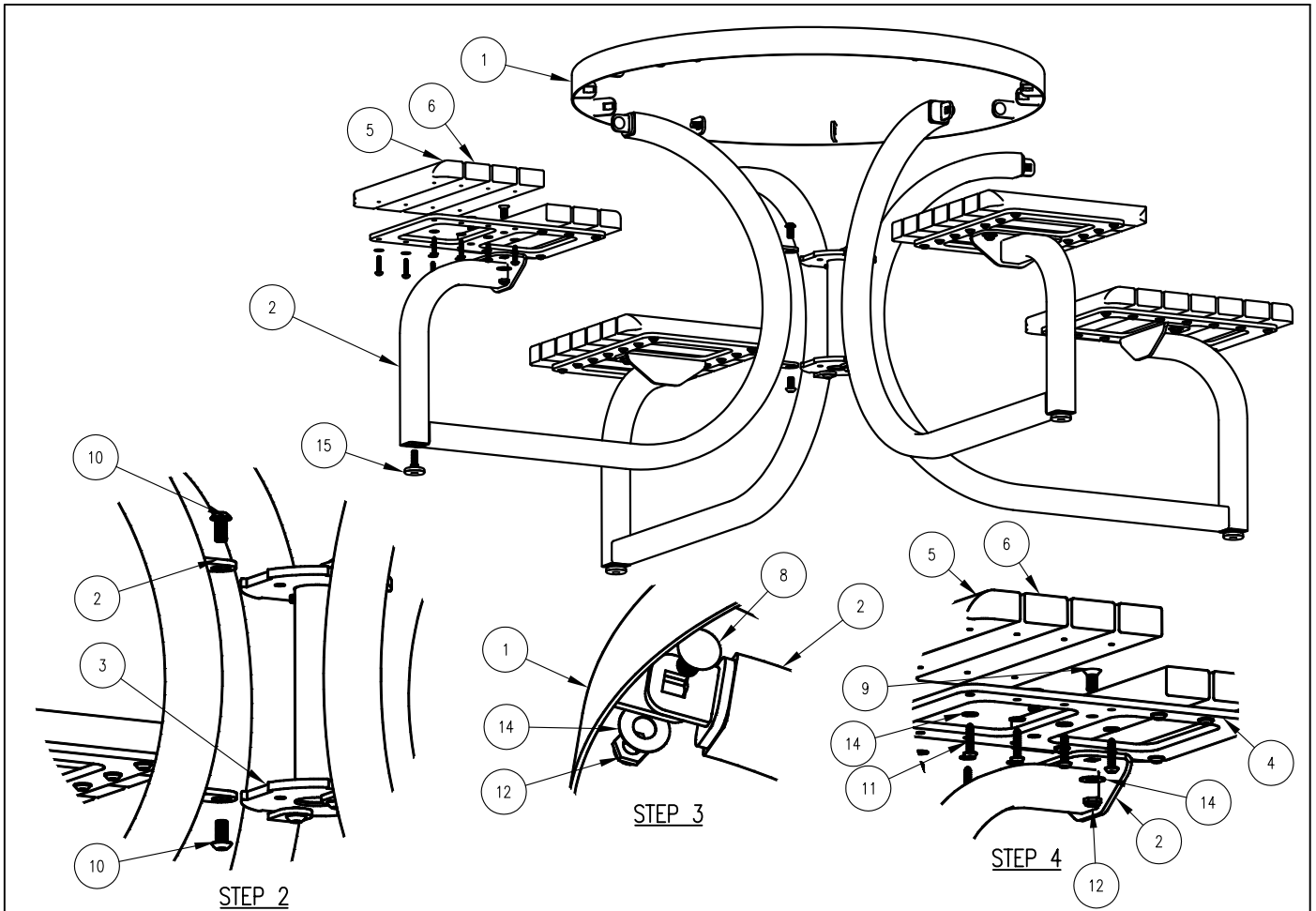

STEP 1:

USE 4 - PCS. TABLE SUPPORT LEG (2)
 4 - PCS. SURFACE MOUNT FOOT PAD (7)
 4 - PCS. 1/2" X 1 1/2" SWIVEL GLIDE (15)
 ATTACH SURFACE MOUNT FOOT PAD (7) OR 1/2" X 1 1/2" SWIVEL GLIDE (15) TO TABLE SUPPORT LEG (2) REPEAT UNTIL ALL SURFACE MOUNT FOOT PAD OR GLIDES ARE ATTACHED.

STEP 2:

USE 1 - PC. 4 SEAT BOLTING COLLAR (3)
 8 - PCS. 1/2" X 1" SS BTN SKT HD CAP SCR (10)
 ATTACH STEP 1 ASSEMBLY TO 4 SEAT BOLTING COLLAR (3) USING HARDWARE (10). TIGHTEN TO SNUG FIT. REPEAT UNTIL ALL STEP 1 ASSEMBLY ATTACHED.

STEP 3:

USE 1 - PC. STL TABLE TOP (1)
 4 - PCS. 1/2" X 1" SS CGE BOLT (8)
 4 - PCS. 1/2" SS. THIN LOCKNUT (12)
 4 - PCS. 1/2" SS. FLAT WASHER (13)
 ATTACH STL TABLE TOP (1) TO STEP 2 ASSEMBLY USING HARDWARE (8, 12 & 13). TIGHTEN TO SNUG FIT.

STEP 4:

USE 4 - PCS. SEAT BOLT PLATE (4)
 8 - PCS. 2" X 3" X 16" EDGE SLAT (5)
 20 - PCS. 2" X 3" X 16" INT'R SLAT (6)
 8 - PCS. 1/2" X 1" SS. FLT SKT HD CAP SCR (9)
 8 - PCS. 1/2" SS. THIN LOCKNUT (12)
 8 - PCS. 1/2" SS. FLAT WASHER (13)
 56 - PCS. 5/16" X 1 1/2" SS. BTN SKT HD LAG (11)
 56 - PCS. 5/16" SS. FLAT WASHER (14)
 ATTACH SEAT BOLT PLATE (4) TO STEP 3 ASSEMBLY USING HARDWARE (9, 12 & 13). TIGHTEN COMPLETELY. REPEAT UNTIL ALL SEAT BOLT PLATE ARE ATTACHED. THEN ATTACHED SLATS TO SEAT BOLT PLATE USING HARDWARE (11 & 14). TIGHTEN TO SNUG FIT. REPEAT UNTIL ALL SLATS ARE ATTACHED.

STEP 5:

UPON COMPLETION OF TABLE ASSEMBLY SQUARE ALL COMPONENTS THEN TIGHTEN ALL HARDWARE.

NOTES:

- 1.) DURING ASSEMBLY PROCEDURE; DO NOT COMPLETELY TIGHTEN HARDWARE.
- 2.) THE ACTUAL PARTS WILL NOT BE NUMBERED; NUMBERS ONLY APPLY TO DRAWING.

ITEM	QTY	PART NO	DESCRIPTION
1	1	0-445-00-01	STL TABLE TOP
2	4	0-445-00-02	TABLE SUPPORT LEG
3	1	0-445-04-03	4 SEAT BOLTING COLLAR
4	4	0-445-30-04	SEAT BOLT PLATE
5	8	0-445-30-05	2" X 3" X 16" EDGE SLAT, WOOD
6	20	0-445-30-06	2" X 3" X 16" INT'R SLAT, WOOD
7	4	0-94-00-02/S-2	SURFACE MOUNT FOOT PAD, PC
8	4	1-11-068	1/2" X 1" SS CGE BOLT
9	8	1-12-014	1/2" X 1" SS FLT SKT HD CAP SCR
10	8	1-12-056	1/2" X 1" SS BTN SKT HD CAP SCR
11	56	1-13-023	5/16" X 1 1/2" SS BTN SKT HD LAG
12	12	1-20-018	1/2" SS THIN NYLON LOCKNUT
14	12	1-22-015	1/2" SS FLAT WASHER
14	56	1-22-017	5/16" SS FLAT WASHER
15	4	5-48-078	1/2" X 1 1/2" SWIVEL GLIDE

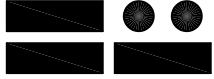
 DuMor, inc. P.O. Box 142 Mifflintown, PA 17059-0142	SCALE :	NONE	TITLE :		TABLE ASSEMBLY	
	DATE DRAWN :	10/11/12	REV.	DRAWING NUMBER	445-34	SHEET
	DRAWN BY :	JSB	A			2 OF 2
	DATE REV. :					
	REV. BY :					