

**NOTES:**

- 1.) ALL STL MEMBERS COATED W/ ZINC RICH EPOXY THEN FINISHED W/ POLYESTER POWDER COATING.
- 2.) 1/2" X 1" SWIVEL GLIDES AND 1/2" X 3 3/4" EXPANSION ANCHOR BOLTS PROVIDED.

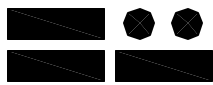

**DuMor, inc.**

P.O. Box 142 Mifflintown, PA 17059-0142

SCALE :	NONE
DATE DRAWN :	6/20/05
DRAWN BY :	AWH
DATE REV. :	
REV. BY :	

TITLE :	CHAIR		
REV. A	DRAWING NUMBER	126-01	SHEET 1 OF 2

**NOTE:**

- 1.) DURING ASSEMBLY PROCEDURE;  
DO NOT COMPLETELY TIGHTEN HARDWARE.
- 2.) THE ACTUAL PARTS WILL NOT BE NUMBERED;  
NUMBERS ONLY APPLY TO DRAWING.

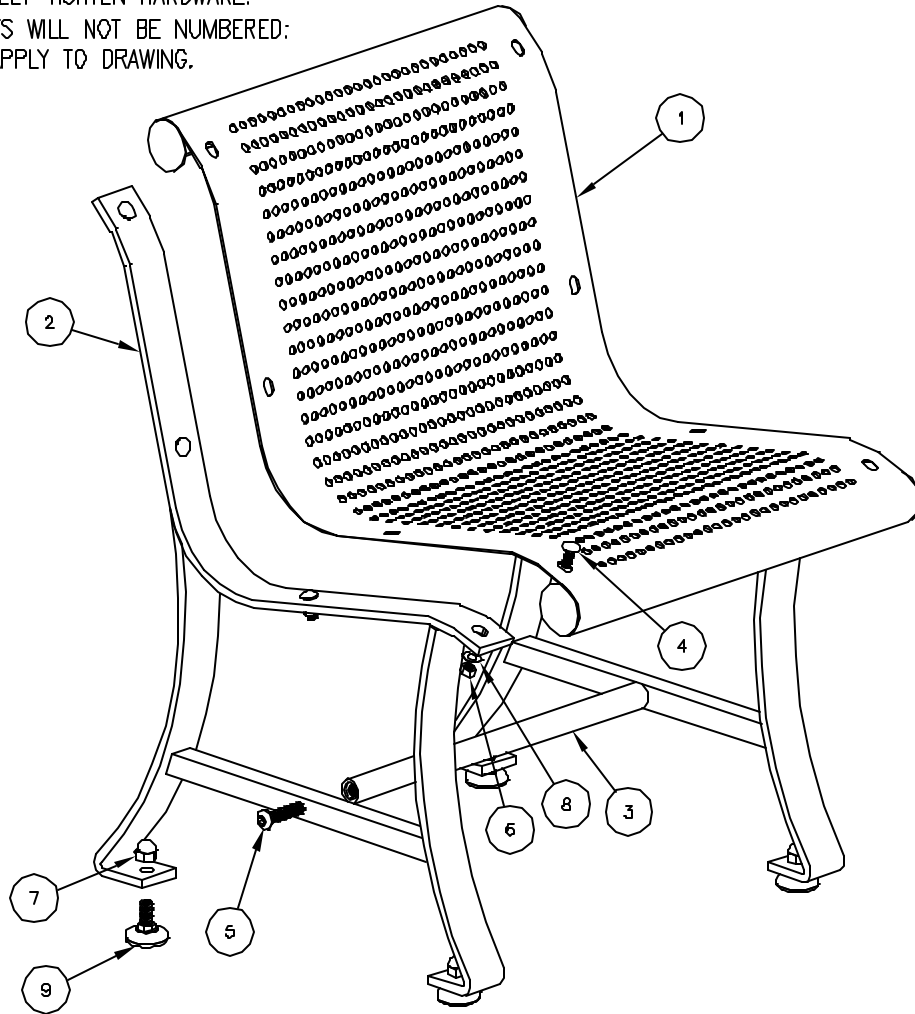

**STEP 3:**

- USE 4 - PCS. 1/2" SS. HEX ACORN NUT ( 7 )
- 4 - PCS. 1/2" X 1" SWIVEL GLIDE ( 9 )
- ATTACH SWIVEL GLIDE ( 9 ) TO STEP 4 ASSEMBLY USING HARDWARE ( 7 ). TIGHTEN TO SNUG FIT. REPEAT UNTIL ALL SWIVEL GLIDES ARE ATTACHED.

**STEP 1:**

- USE 2 - PCS. SEAT SUPPORT FRAME ( 2 )
- 1 - PC. 3/4" I.D. PIPE BRACE ( 3 )
- 2 - PCS. 1/2" X 2" SS. BTN. SKT. HD. CAP SCR. ( 5 )
- ATTACH 3/4" I.D. PIPE BRACE ( 3 ) TO SEAT SUPPORT FRAME ( 2 ) USING HARDWARE ( 5 ). TIGHTEN TO SNUG FIT.

**STEP 4:**

UPON COMPLETION OF SEAT ASSEMBLY SQUARE ALL COMPONENTS THEN TIGHTEN ALL HARDWARE.

**STEP 2:**

- USE 1 - PC. 14 GA. PERF. STL. SEAT ( 1 )
- 8 - PCS. 3/8" X 1" SS. CGE. BOLT ( 4 )
- 8 - PCS. 3/8" SS. HEX NUT ( 6 )
- 8 - PCS. 3/8" SS. FLAT WASHER ( 8 )
- ATTACH 14 GA. PERF. STL. SEAT ( 1 ) TO STEP 1 ASSEMBLY USING HARDWARE ( 4, 6, & 8 ). TIGHTEN TO SNUG FIT.

ITEM	QTY	PART NO	DESCRIPTION
1	1	0-101-00-02	14 GA PERF STL SEAT
2	2	0-128-01	CHAIR SUPPORT FRAME
3	1	0-126-03	3/4" SCH 40 PIPE BRACE 17"
4	8	1-11-028	3/8" X 1" SS CGE BOLT
5	2	1-12-051	1/2" X 2" SS BTN SKT HD CAP SCR
6	8	1-21-007	3/8" SS HEX NUT
7	4	1-21-018	1/2" SS HEX ACORN NUT
8	8	1-22-024	3/8" SS FLAT WASHER
9	4	5-48-096	1/2" X 1" SWIVEL GLIDE

 <b>DuMor, inc.</b> P.O. Box 142 Mifflintown, PA 17059-0142	SCALE :	NONE	TITLE : <b>SEAT ASSEMBLY</b>	
	DATE DRAWN :	6/20/05		
	DRAWN BY :	AWH	REV.	DRAWING NUMBER
	DATE REV. :		A	126-01
	REV BY :			SHEET
			2 OF 2	