

DETAIL OF BOLLARD WITH SLEEVE

DETAIL OF CAP WITH SLEEVE

NOTES

- 1.) STL. MEMBERS COATED W/ ZINC RICH EPOXY THEN FINISHED W/ POLYESTER POWDER COATING.
- 2.) LOCKING DEVICE PROVIDED BY OTHER.



DuMor, inc.

P.O. Box 142 Mifflintown, PA 17059-0142

SCALE : NONE
 DATE DRAWN : 11/17/06
 DRAWN BY : HMD
 DATE REV. : 01/11/07
 REV. BY : ESS

TITLE :
 REV. B

BOLLARD

DRAWING NUMBER 402-36/S-1SL

SHEET 1 OF 2

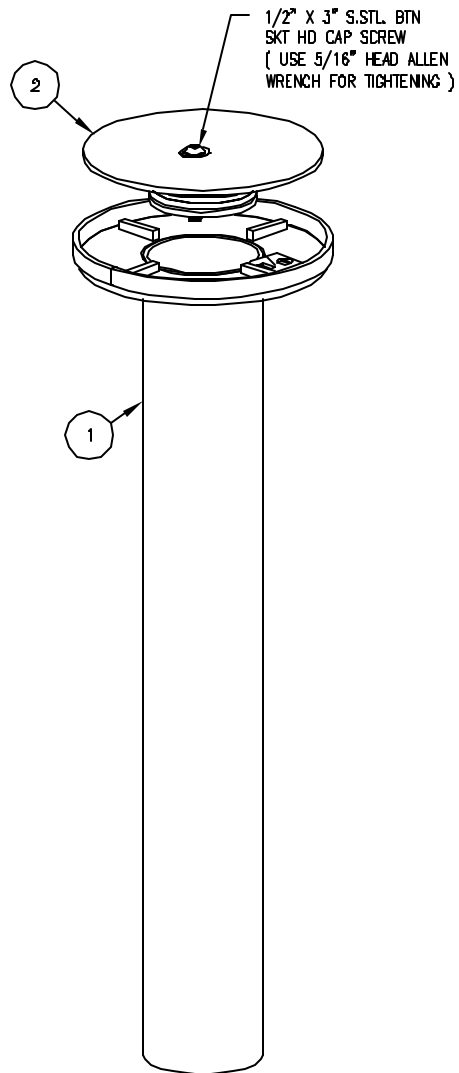
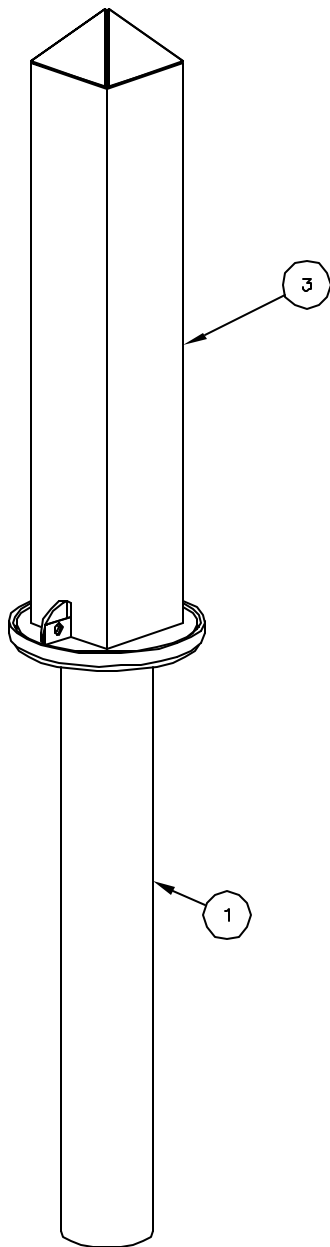

NOTES:

1. SET SLEEVE INTO FOOTER HOLDING PLUM, SQUARE AND HEIGHT SHOWN.
2. SLIDE BOLLARD INTO SLEEVE AFTER CONCRETE HAS HARDENED. BE SURE TO HAVE HINGE TAB SLIDE INTO BOLLARD BASE PLATE SLOT FOR LOCKING.
3. FOR USE OF CAP. WHEN BOLLARD IS REMOVED, PLACE CAP INTO SLEEVE. TIGHTEN CAP BY USING 1/2" X 3" BUTTON HEAD BOLT. THIS WILL COMPRESS THE RUBBER WASHERS THICKNESS AND EXPAND THE DIAMETER TO FIT SNUG TO SLEEVE.

ITEM	QTY	PART NO	DESCRIPTION
1	1	D-400-02	STL BOLLARD SLEEVE W/ HINGE
2	1	D-400-03	BOLLARD SLEEVE CAP ASSEMBLY
3	1	D-402-36-01/1SL	36" REMOVABLE BOLLARD, EMBED FOR SLEEVE

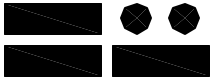
 DuMor, inc. P.O. Box 142 Mifflintown, PA 17059-0142	SCALE : NONE	TITLE : BOLLARD	
	DATE DRAWN : 11/17/05	REV. : A	DRAWING NUMBER 402-36/S-15L
	DRAWN BY : HMD	SHEET 2 OF 2	
	DATE REV. : 01/11/07	REV. BY : ESS	